



US007082339B2

(12) **United States Patent**
Murray et al.

(10) **Patent No.:** **US 7,082,339 B2**
(45) **Date of Patent:** **Jul. 25, 2006**

- (54) **HOME AUTOMATION SYSTEM**
- (75) Inventors: **Christopher Murray**, Baltimore, MD (US); **Cory Sorice**, Towson, MD (US)
- (73) Assignee: **Black & Decker Inc.**, Newark, DE (US)
- (*) Notice: Subject to any disclaimer, the term of this patent is extended or adjusted under 35 U.S.C. 154(b) by 503 days.

(21) Appl. No.: **10/418,022**

(22) Filed: **Apr. 17, 2003**

(65) **Prior Publication Data**
US 2003/0198938 A1 Oct. 23, 2003

- Related U.S. Application Data**
- (60) Provisional application No. 60/373,348, filed on Apr. 17, 2002.
- (51) **Int. Cl.**
G05B 15/00 (2006.01)
- (52) **U.S. Cl.** **700/83; 700/9; 700/274; 700/282; 700/65; 700/79**
- (58) **Field of Classification Search** **700/83, 700/9, 274, 282, 79, 65; 340/310.01, 310.02, 340/310.04, 310.06, 310.11, 310.12, 310.14, 340/310.16; 434/429, 224, 365, 379, 382**
See application file for complete search history.

- (56) **References Cited**
U.S. PATENT DOCUMENTS
- 4,200,862 A * 4/1980 Campbell et al. 340/310.11
- 4,638,299 A * 1/1987 Campbell 370/501
- 4,712,398 A 12/1987 Clarkson et al.
- 4,755,792 A 7/1988 Pezzolo et al.

4,815,202 A	3/1989	Jackson et al.	
4,848,115 A	7/1989	Clarkson et al.	
4,887,442 A	12/1989	Lavelle	
4,902,882 A	2/1990	Lavelle	
5,491,463 A *	2/1996	Sargeant et al.	340/310.16
5,579,221 A *	11/1996	Mun	700/83
5,905,442 A	5/1999	Mosebrook et al.	
5,929,748 A	7/1999	Odinak	
5,996,383 A	12/1999	Adelmeyer et al.	
6,091,320 A	7/2000	Odinak	
6,158,259 A	12/2000	Schmitz et al.	
6,331,813 B1 *	12/2001	Belliveau	340/310.11
6,532,152 B1 *	3/2003	White et al.	361/692
2003/0198938 A1 *	10/2003	Murray et al.	434/429
2005/0162273 A1 *	7/2005	Yoon et al.	340/539.14

OTHER PUBLICATIONS

Lutron Homeworks Interactive HWI-HHP-LD Hand-Held Programmer Quick Start Guide (Rev. A May 2002).

(Continued)

Primary Examiner—Anthony Knight
Assistant Examiner—Thomas Pham
(74) *Attorney, Agent, or Firm*—Harness, Dickey & Pierce, P.L.C.

(57) **ABSTRACT**

An improved home automation system that permits the user of the system to remotely control the operation of various devices. The system is packaged in a manner that “walks” the user through the initialization process to thereby reduce or eliminate errors associated with the initialization and set-up of the system. Furthermore, the configuration permits the user to initialize the system without the use of tools, such as screwdrivers. The system is configured with improved functionality that permits the user to readily control individual devices and/or selected groups of devices with a powerful hand-held remote transmitter.

8 Claims, 11 Drawing Sheets

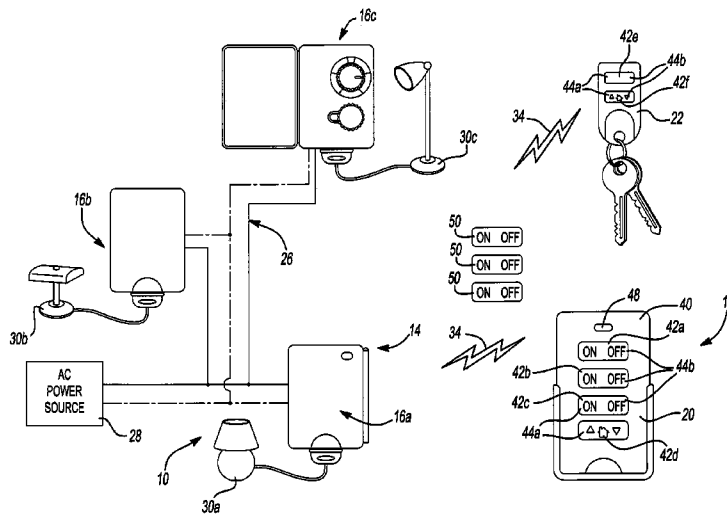

OTHER PUBLICATIONS

Lutron Homeworks Interactive HWI-HHP-LD Hand-Held Programmer User's Guide (Rev. A May 2002).

X10.COM Lamp Module LM465 Product Guide (Nov. 2002).

X10.COM Transceiver Module RR501 Installation and Operating Instructions (Nov. 2002).

X10.COM Transceiver TM751 Installation and Operating Instructions (Sep. 2001).

X10.COM KR22A Credit Card Controller Installation and Operating Instructions (Sep. 2001).

* cited by examiner

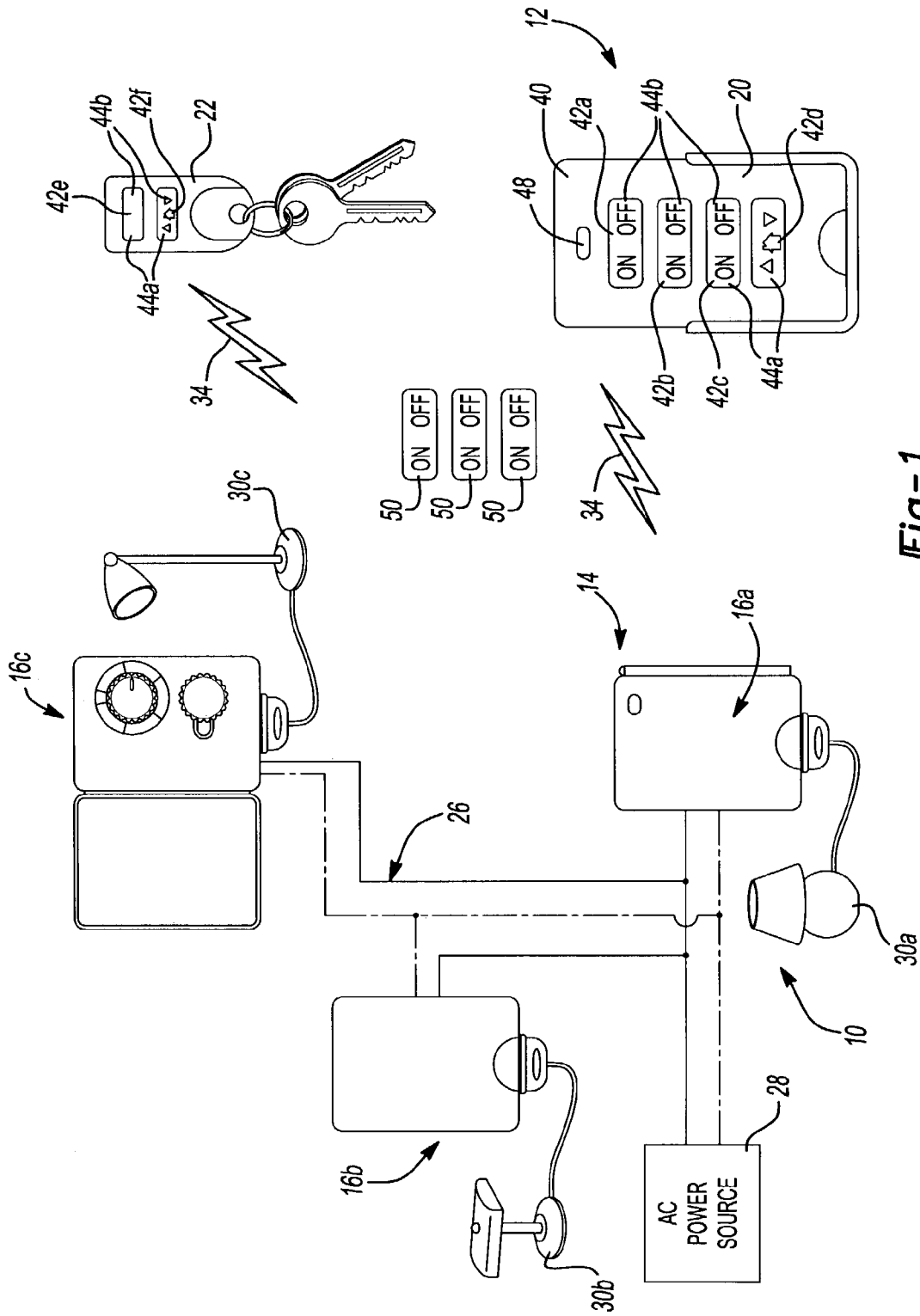

Fig-1

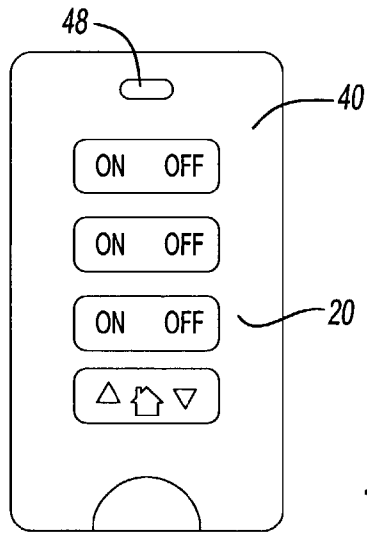

Fig-2

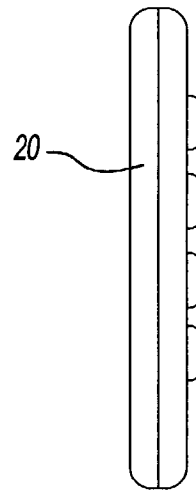

Fig-3

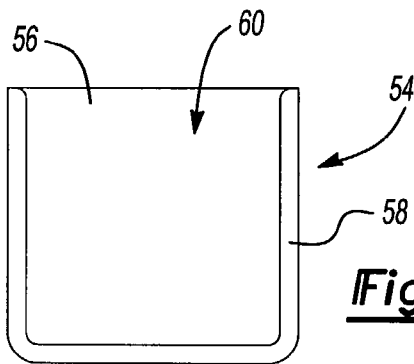

Fig-4

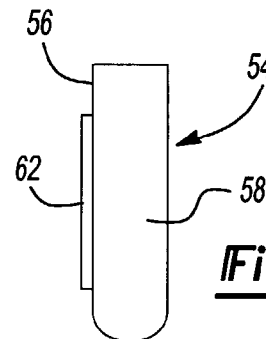

Fig-5

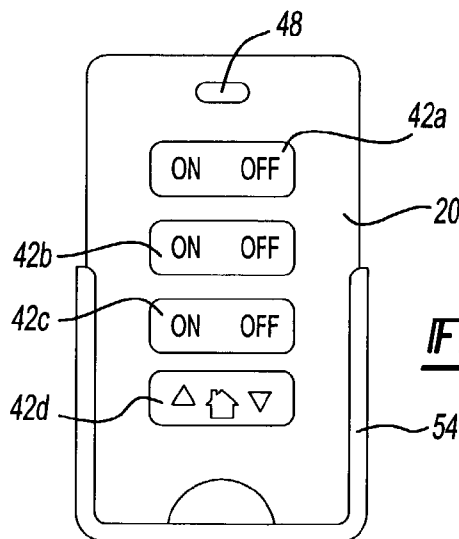

Fig-6

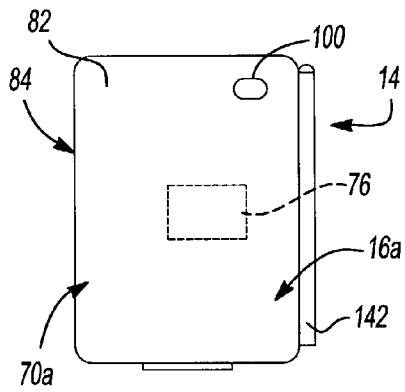

Fig-7

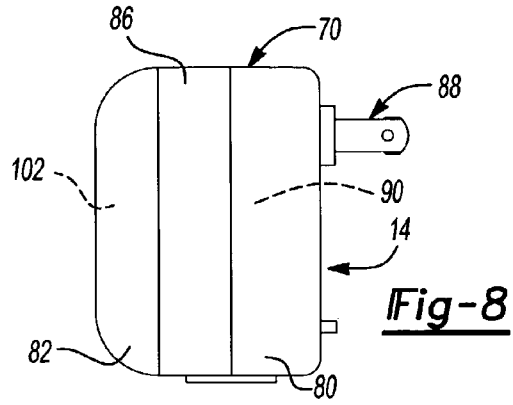

Fig-8

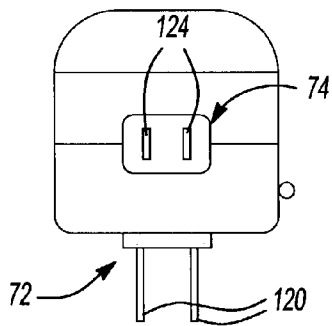

Fig-9

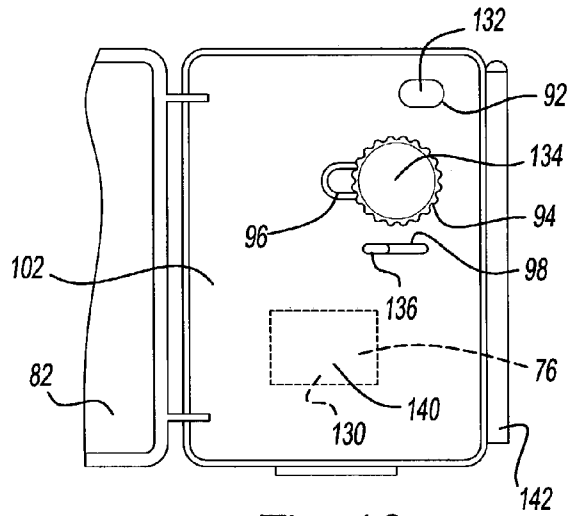

Fig-10

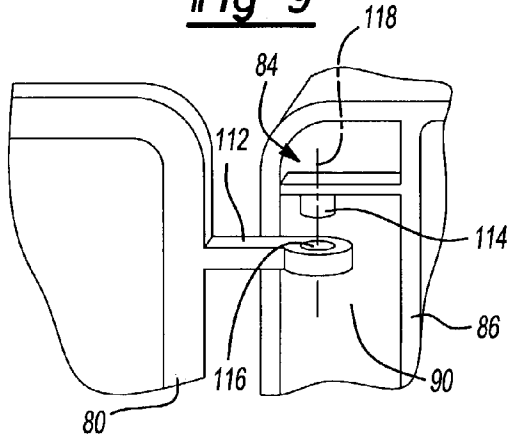
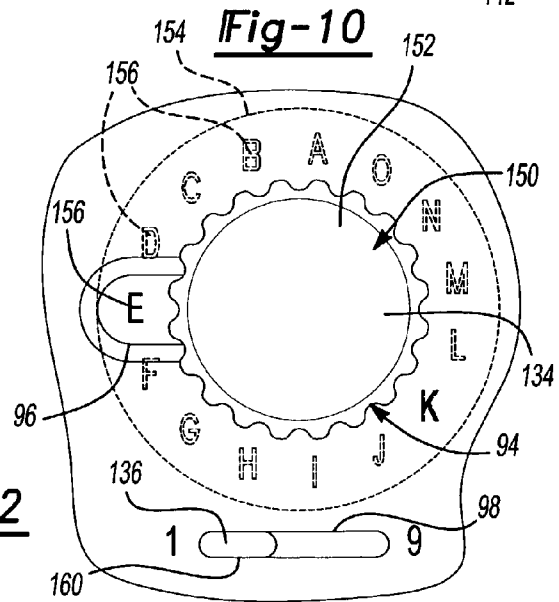

Fig-11

Fig-12



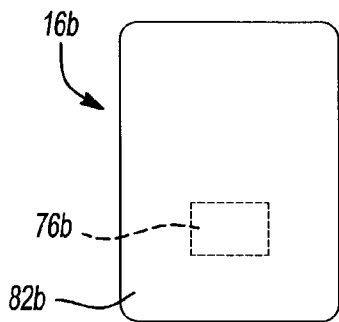

Fig-13

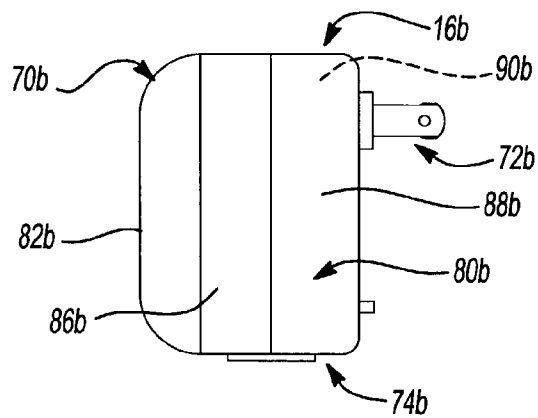

Fig-14

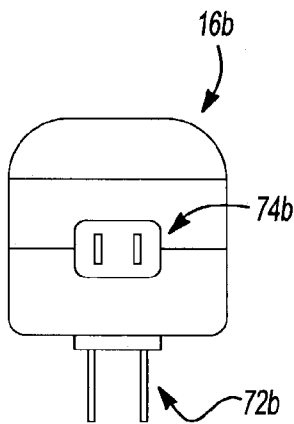

Fig-15

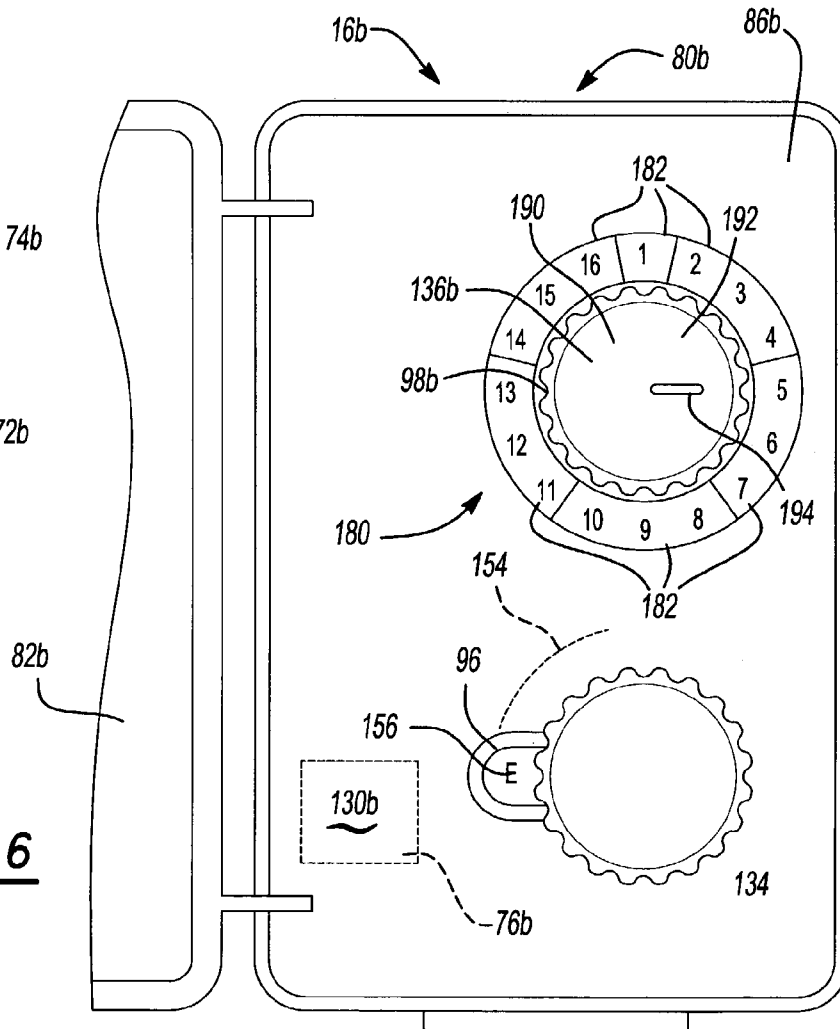

Fig-16

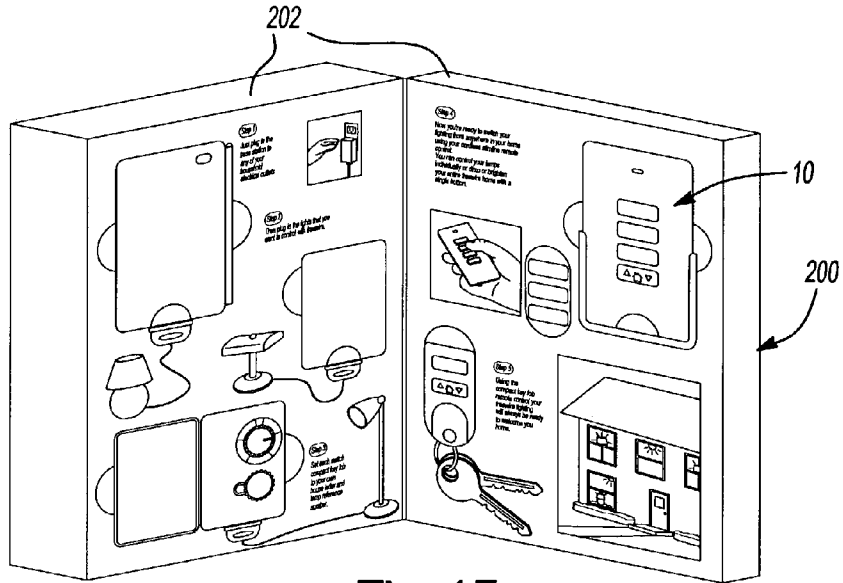

Fig-17

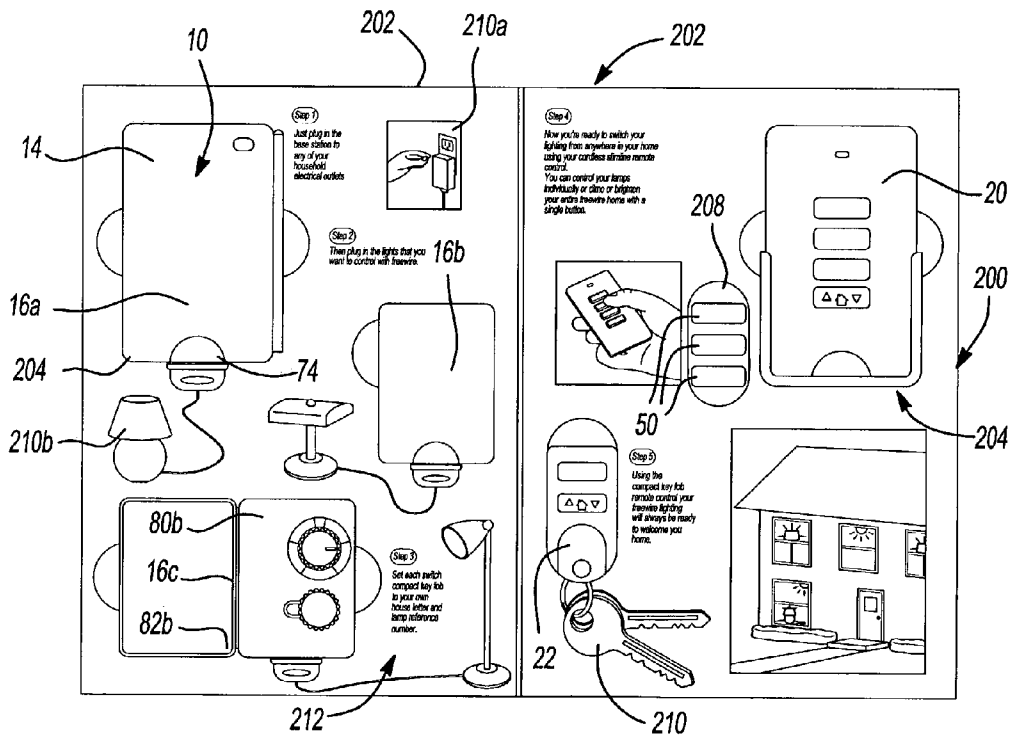

Fig-18

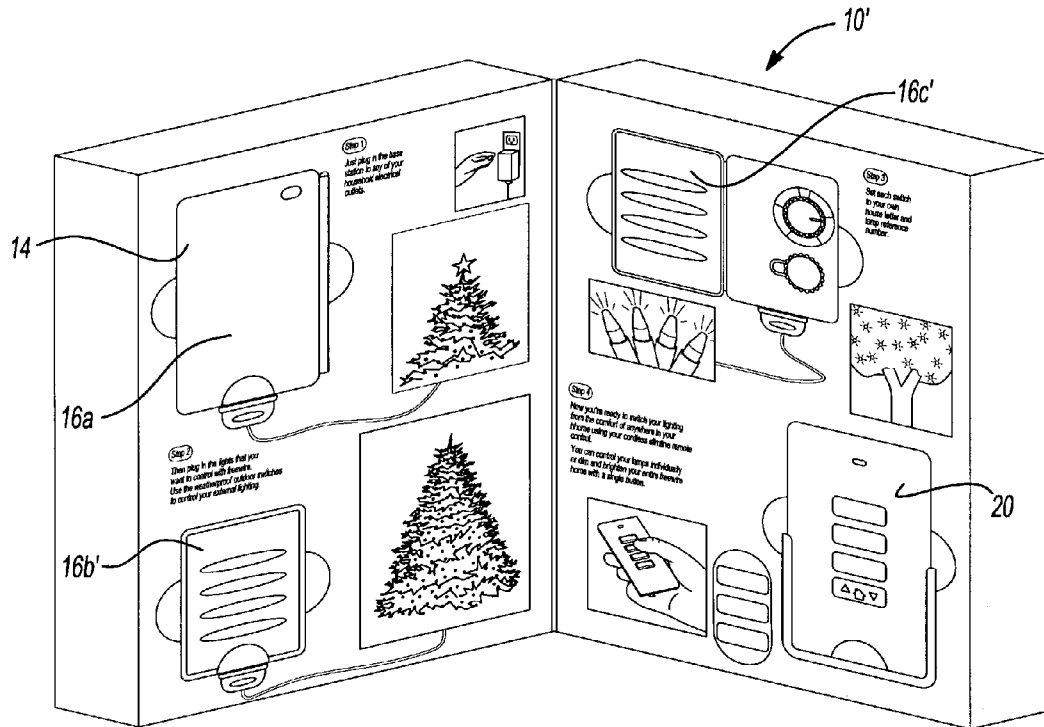

Fig-19

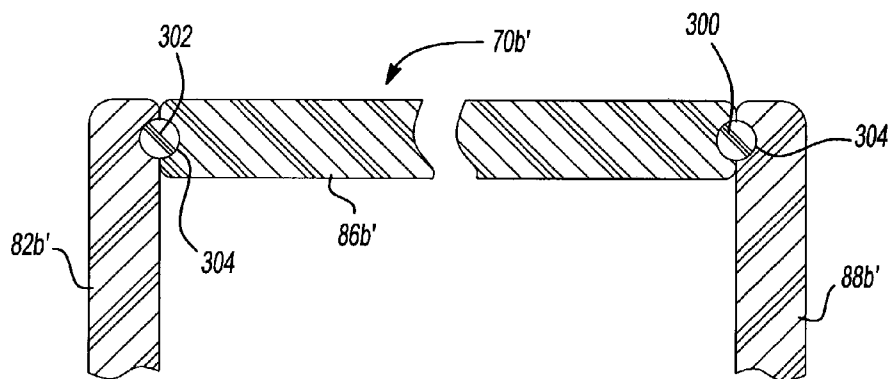

Fig-20

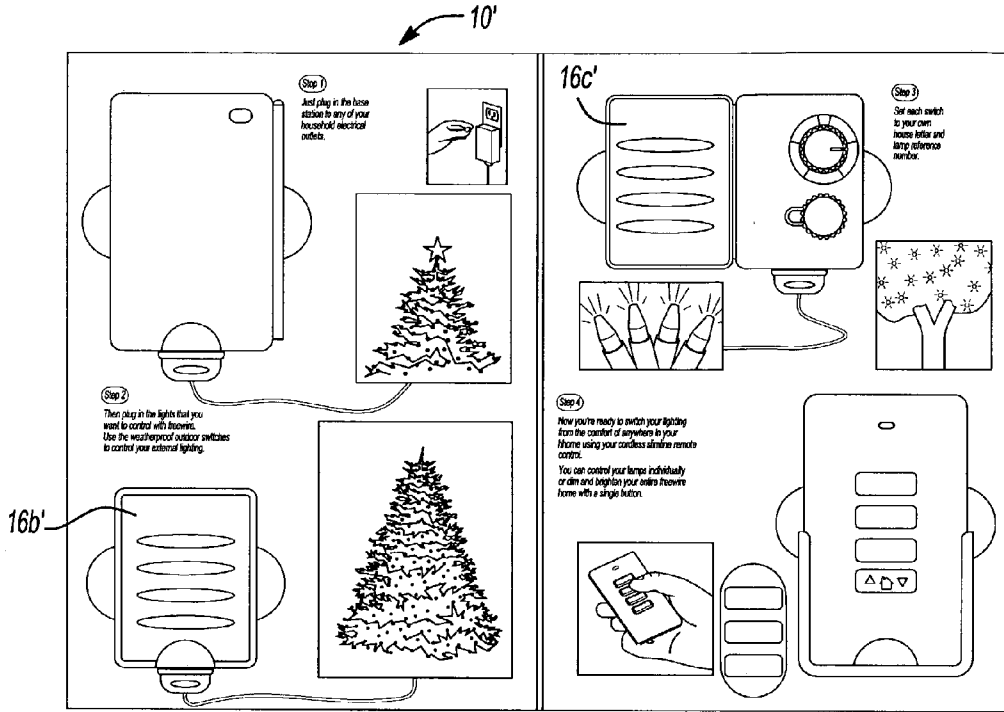

Fig-21

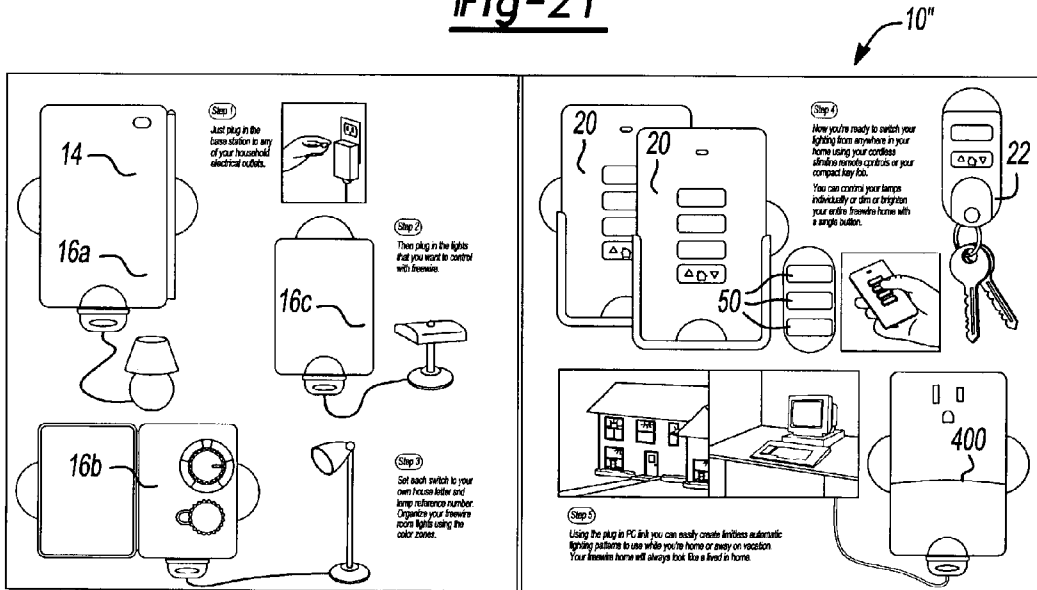

Fig-22

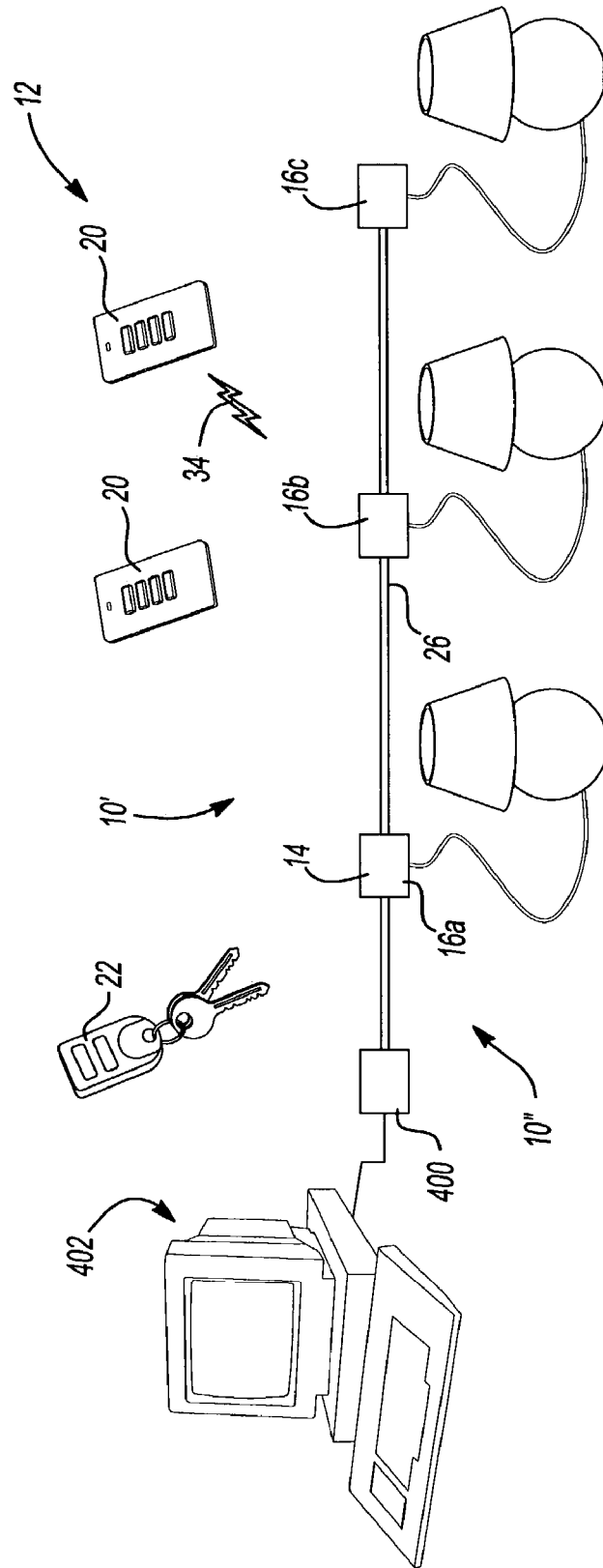

Fig-23

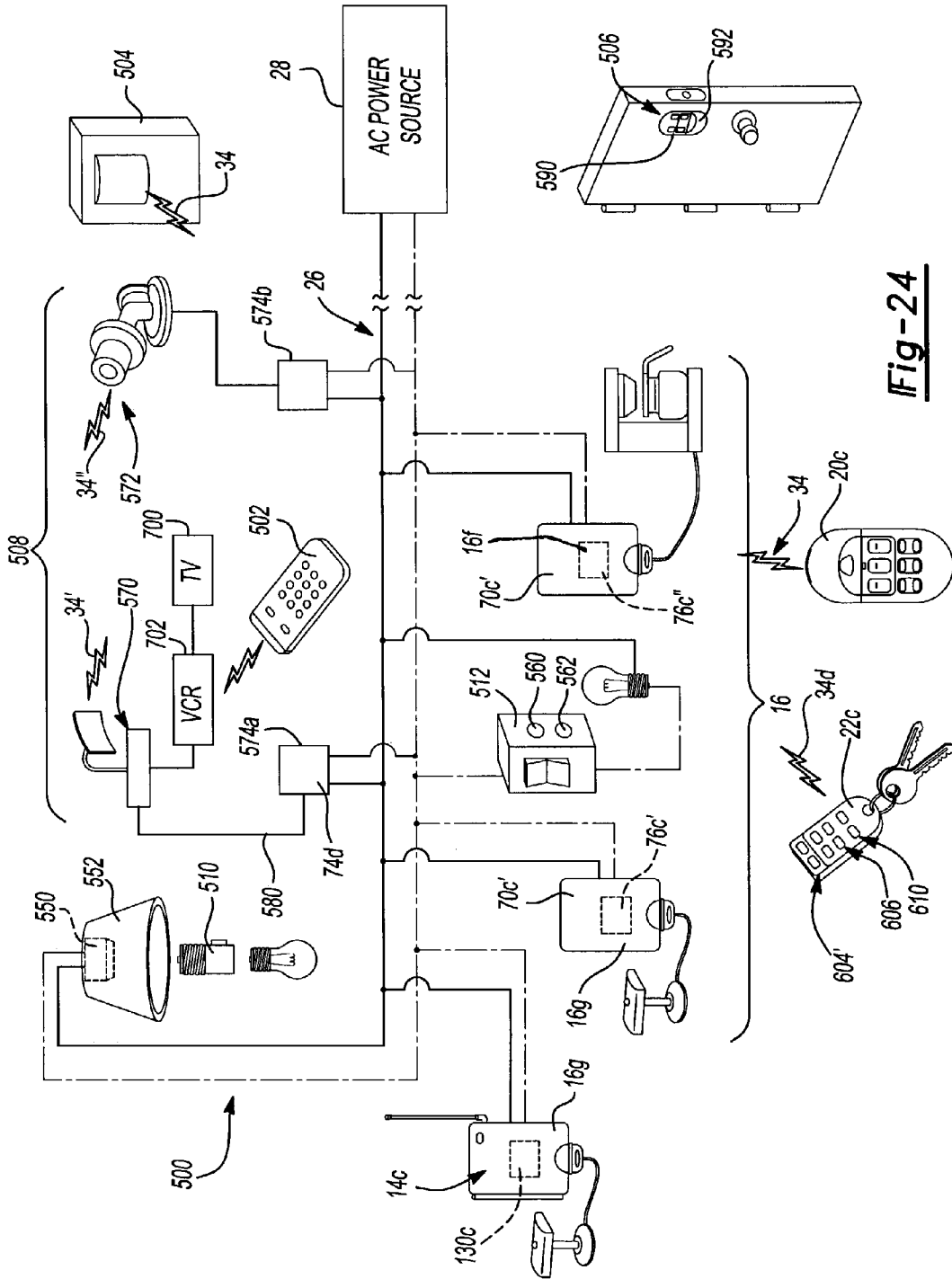

Fig-24

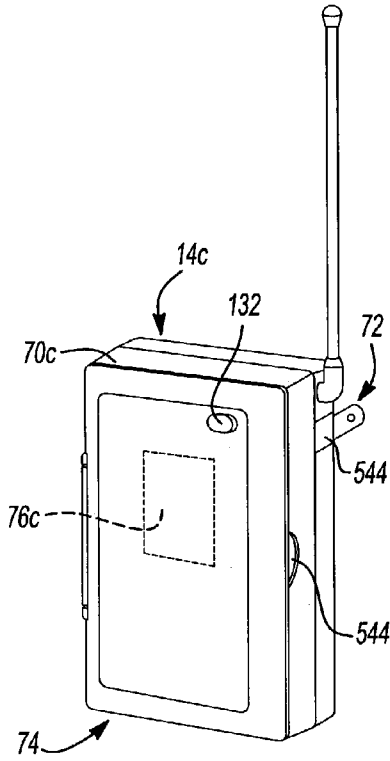

Fig-25

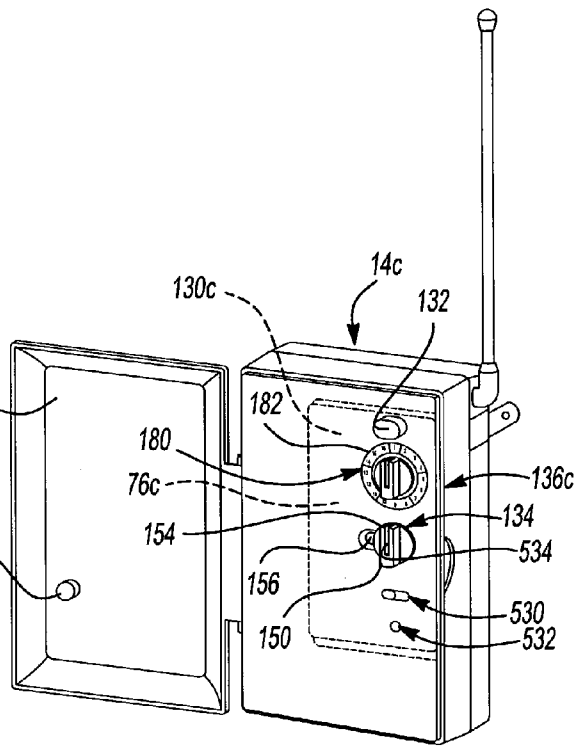
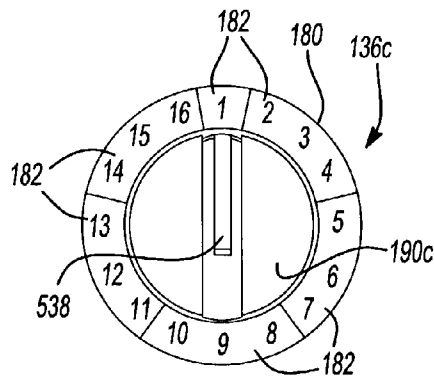

Fig-26



RUN 530 LEARN

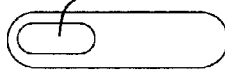

Fig-27

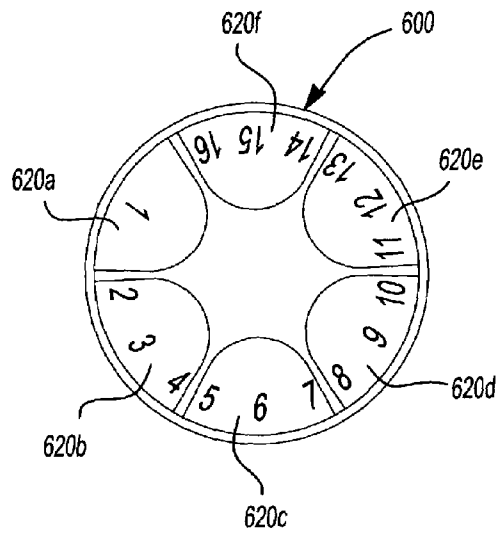

Fig-28

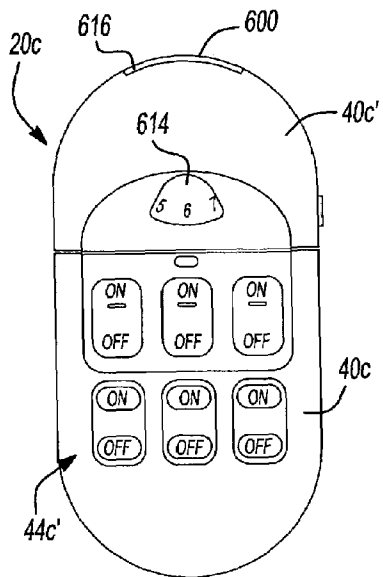

Fig-29

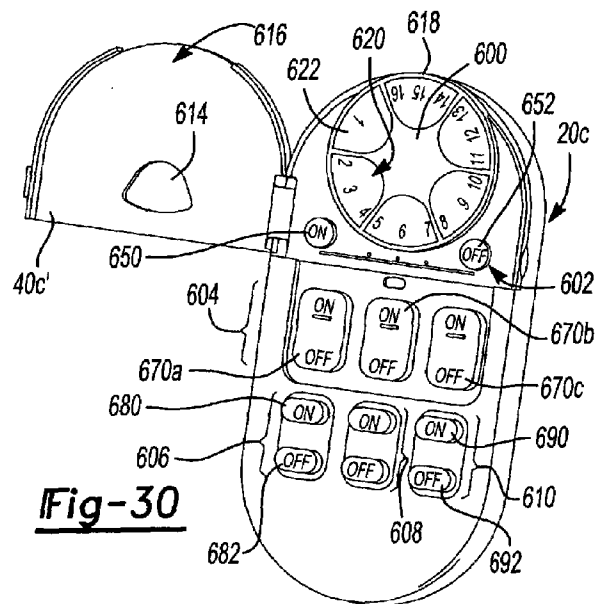

Fig-30

HOME AUTOMATION SYSTEM**CROSS-REFERENCE TO RELATED APPLICATIONS**

This application claims the benefit of U.S. Provisional Patent Application No. 60/373,348 filed Apr. 17, 2002 entitled "Home Automation System".

FIELD OF THE INVENTION

The present invention generally relates to the control of electrical devices and more particularly to the control of electrical devices from remote locations using electrical power wiring.

BACKGROUND OF THE INVENTION

Due to the plethora of specialty stores, publications and television programs that are related to home improvement, renovation and construction, modern consumers are increasingly aware of advancements in technologies relating to the maintenance and operation of homes. One increasingly popular trend in home technology concerns home automation wherein various electrical devices (e.g., lights, stereos) and/or security devices (e.g., motion sensors, alarms) are integrated into a house. Automation systems that are incorporated into newly constructed homes generally tend to utilize one or more discrete systems of control wires that facilitate communication between a controller and the electrical and/or security devices.

When an automation system is to be integrated into an existing house, the installation of a discrete set of control wires can be very complicated and costly, particularly if portions of the house, such as walls and ceilings, become damaged during the installation of the control wires. In view of these difficulties, many products have been developed which utilize the existing AC power distribution wires to facilitate communication between a controller and the electrical and/or security devices. These products typically modulate a control signal over the power wires at a frequency that is well above the conventional 60 Hz frequency of AC electrical power that is carried by the power wires.

The protocol known as "X10" is a common protocol for providing communications between a controller and electrical and security devices over electrical power wires. The X10 signal is composed of a series of 5 volt, 121 kHz pulses having duration of 1 millisecond, positioned at zero crossings of the 60 Hz AC electrical power. Each pulse corresponds to a binary 1, and the absence of a pulse corresponds to a binary 0. A single X10 command or message consists of a 22 bit word that is obtained from eleven complete cycles of the AC electrical power. All X10 receivers that are electrically coupled (i.e., plugged into) the AC electrical power will receive all of the messages that are transmitted over the AC power wires. The receipt of a message by a receiver, however, will not automatically initiate a response in the receiver. In this regard, each message that is transmitted over the AC power lines carries a receipt address and only the X10 receivers whose address matches the receipt address will respond to a message.

While such X10 automation systems are relatively inexpensive and reliable, several drawbacks of the heretofore known X10 automation systems have been identified. One such drawback relates to the set-up of a typical X10 automation system which has been identified by some consumers as being confusing and difficult. In this regard, it is to be

noted that up to 256 different addresses may be available in a given home automation system and that the receipt address in the message transmitted by the transmitting device (e.g., the controller) must match the address of the receiving device (e.g., a lamp switch) to permit the receiving device to be controlled in a desired manner. Furthermore, tools, such as screwdrivers, are routinely required to manipulate the switches of the various components of the known home automation systems to set the address of the component to a desired address. Moreover, while all of the known home automation systems include installation directions, their components are not packaged in a manner that renders the installation of their components intuitively obvious so that typical home consumers.

Another drawback concerns the overall appearance of the components of the known X10 automation systems. In this regard, many of the available home automation systems include components having a housing with one or more apertures through which extend addressing switches. The presence of the switches, as well as their labeling, provides the component with an appearance that may not be desirable to the homeowner.

Yet another drawback concerns the relative robustness of the components of the known X10 automation systems. In this regard, the components are generally rated for inside use and are not subjected to the temperature extremes and moisture that are commonly experienced by electrical and security devices that are found or used out of doors.

SUMMARY OF THE INVENTION

In one preferred form, the present invention provides an improved home automation system having a clean and aesthetically pleasing appearance.

In another preferred form, the present invention provides an improved home automation system that is packaged in a manner that renders the process of initializing the home automation system more intuitively obvious.

In another preferred form, the present invention provides an improved home automation system that is configured in a manner that renders its operation more intuitively obvious.

In a further preferred form, the present invention provides an improved home automation system that is suited for both indoor and outdoor use.

In yet another preferred form, the present invention provides an improved home automation system that includes a hand-held remote transmitter that permits individual devices and/or pre-selected groups of devices to be remotely controlled by the user of the system.

In still another preferred form, the present invention provides an improved home automation system that may be initialized without the use of tools.

Further areas of applicability of the present invention will become apparent from the detailed description provided hereinafter. It should be understood that the detailed description and specific examples, while indicating the preferred embodiment of the invention, are intended for purposes of illustration only and are not intended to limit the scope of the invention.

BRIEF DESCRIPTION OF THE DRAWINGS

Additional advantages and features of the present invention will become apparent from the subsequent description and the appended claims, taken in conjunction with the accompanying drawings, wherein:

3

FIG. 1 is a schematic illustration of a home automation system constructed in accordance with the teachings of the present invention;

FIG. 2 is a front elevational view of a portion of the home automation system of FIG. 1 illustrating the hand-held transmitter in greater detail;

FIG. 3 is a side view of the hand-held transmitter;

FIG. 4 is a front elevational view of a portion of the home automation system of FIG. 1 illustrating the mounting cradle in greater detail;

FIG. 5 is a left side elevational view of the mounting cradle;

FIG. 6 is a front elevational view of the hand-held transmitter as received into the mounting cradle;

FIG. 7 is a front elevational view of a portion of the home automation system of FIG. 1 illustrating the messenger hub in greater detail;

FIG. 8 is a right elevational view of the messenger hub;

FIG. 9 is a bottom plan view of the messenger hub;

FIG. 10 is a front elevational view of a portion of the messenger hub illustrating the housing cover in an opened condition;

FIG. 11 is a partially exploded and broken away view of the messenger hub illustrating the hinge mechanism in greater detail;

FIG. 12 is an enlarged portion of FIG. 10, illustrating the control address selector and the switch address selector in greater detail;

FIG. 13 is a front elevational view of a portion of the home automation system of FIG. 1 illustrating a switch in greater detail;

FIG. 14 is a right side elevational view of the switch;

FIG. 15 is a bottom plan view of the switch;

FIG. 16 is a front elevational view of the switch illustrating the housing cover in an opened condition;

FIG. 17 is a perspective view of the home automation system of FIG. 1 as packaged in accordance with the teachings of the present invention;

FIG. 18 is a front elevational view of the home automation system and packaging of FIG. 17, illustrating the packaging with the covers in an open condition;

FIG. 19 is a perspective view of the home automation system constructed in accordance with the teachings of another preferred embodiment of the present invention, the home automation system being illustrated in a packaged condition;

FIG. 20 is a sectional view of a portion of one of the switches of the home automation system of FIG. 19;

FIG. 21 is a front elevational view of the home automation system of FIG. 19 as packaged in accordance with the teachings of the present invention;

FIG. 22 is a schematic view of a home automation system constructed in accordance with the teachings of another preferred embodiment of the present invention, the home automation system being illustrated in a packaged condition;

FIG. 23 is a schematic view of the home automation system of FIG. 22;

FIG. 24 is a schematic view of a home automation system constructed in accordance with the teachings of another preferred embodiment of the present invention;

FIG. 25 is a perspective view of a portion of the home automation system of FIG. 24, illustrating the messenger hub in greater detail;

FIG. 26 is a view similar to FIG. 25 but illustrating the cover of the messenger hub in an open position;

4

FIG. 27 is a front view of a portion of the messenger hub illustrating the configuration of the switch address selector in greater detail;

FIG. 28 is a front view of a portion of the messenger hub illustrating the configuration of the run/learn switch;

FIG. 29 is a front view of a portion of the home automation system of FIG. 24, illustrating the hand-held remote transmitter in greater detail; and

FIG. 30 is a perspective view of the hand-held remote transmitter with the cover in an open position.

DETAILED DESCRIPTION OF THE PREFERRED EMBODIMENTS

With reference to FIG. 1 of the drawings, a home automation system constructed in accordance with the teachings of the present invention is generally indicated by reference numeral 10. The home automation system 10 is illustrated to include a plurality of remote transmitters 12, a messenger hub 14 and a plurality of switches (e.g., switches 16a, 16b and 16c). The remote transmitters 12 include a hand-held transmitter 20 and a key fob transmitter 22. The home automation system 10 is illustrated in conjunction with a power wire system 26 that provides AC electrical power from an AC power source 28 to the home automation system 10, as well as various electrical devices, such as lamps 30a, 30b and 30c.

The hand-held transmitter 20 is conventionally operable for transmitting a plurality of a radio frequency (RF) signals 34 to communicate an RF command to the messenger hub 14. In the particular embodiment illustrated, the hand-held transmitter 20 includes a housing 40 that houses four keys 42a, 42b, 42c and 42d, each of which include two function switches 44a and 44b. Each of the function switches 44a and 44b permit a key to be associated with two different functions. Those skilled in the art will appreciate in view of this disclosure that the hand-held transmitter 20 and the messenger hub 14 may be configured to communicate via any suitable form of electromagnetic wave communication. In the particular embodiment provided, each key 42a, 42b, 42c and 42d is analogous to a dimmer switch, with the function switches 44a and 44b being associated with function commands that are intended to progressively increase or reduce, respectively, the power that is output from an associated switch. Accordingly, a lamp that is plugged into the switch would increasingly illuminate or dim in response to the actuation of the function switches 44a and 44b, respectively, of the key that is associated with the switch.

Keys 42a, 42b and 42c are programmable and permit the user of the home automation system 10 to assign both a requested controller address and a requested device address to a given one of the keys 42a, 42b and 42c such that when one of the function switches 44a and 44b is pressed, the handheld transmitter will generate an RF command 34 that includes the requested controller address for that particular key, the requested device address for that particular key, and a function command (e.g., progressively dim or progressively illuminate by controlling the amount of power that is output from the switches 16a, 16b and 16c) that is associated with the function switch.

In the particular embodiment provided, the key 42d is also programmable, but only permits the user of the home automation system 10 to assign a requested controller address. When one of the function switches 44a or 44b for the key 42d is pressed, the hand-held transmitter will generate an RF command 34 that includes the requested controller address, along with a function command that indi-

ates to the messenger hub **14** that all of the switches **16a**, **16b** and **16c** should be progressively dimmed or illuminated, respectively.

Those skilled in the art will appreciate that the requested controller address need not be the same for each of the keys **42a**, **42b**, **42c** and **42d**, for example, if the home automation system **10** included more than one messenger hub **14**, as will become apparent from the discussion below. Those skilled in the art will also appreciate that the keys **42a**, **42b**, **42c** and **42d** and their function switches **44a** and **44b** may be configured somewhat differently. For example, the function switches **44a** and **44b** may be configured in a toggle style, wherein the function switch **44a** is associated with an "on" (i.e., powered) function or condition and the function switch **44b** is associated with an "off" (i.e., unpowered) function or condition. Alternatively, each function switch **44a** and **44b** may be configured to generate a function command that is specific to a particular one of the switches **16a**, **16b** and **16c**. In this latter embodiment, the messenger hub **14** may respond to a function command by controlling an associated one of the switches **16a**, **16b** and **16c** to toggle between a powered and an unpowered condition, or to progressively increase or decrease the power that is output from the associated one of the switches **16a**, **16b** and **16c** until a maximum or minimum power level, respectively, has been achieved and there after fully decreasing or increasing, respectively, the power that is output from the associated one of the switches **16a**, **16b** and **16c** to a minimum or maximum power level, respectively.

The keys **42a**, **42b**, **42c** and **42d** are programmed in a conventional manner and as such, details concerning the programming of the hand-held transmitter need not be discussed in detail herein. Briefly, a programming mode, which is indicated by the illumination of a light **48** on the hand-held transmitter **20**, is entered by actuating the function switches **44a** and **44b** of the keys **42a**, **42b**, **42c** and **42d** in a predetermined manner. The programming mode permits the user of the home automation system **10** to program a requested controller address for each of the keys **42a**, **42b**, **42c** and **42d**, as well as a requested device address for each of the keys **42a**, **42b** and **42c**. Optionally, the function switches **44a** and **44b** for the keys **42a**, **42b**, **42c** and/or **42d** may also be programmable, such that the user of the home automation system **10** may assign a desired function command to each of the function switches **44a** and **44b**.

A key cover **50** is provided for each of the keys **42a**, **42b** and **42c**, which permits the user of the home automation system **10** to readily correlate each key **42a**, **42b** and **42c** to a particular switch. Each key cover **50** is formed from a flexible plastic material that is contoured to snap-fit onto and matingly engage one of the keys **42a**, **42b** and **42c**. The key cover **50** is not provided for key **42d** as key **42d** is associated with the operation of all of the switches in the embodiment illustrated.

In the particular example provided, each key cover **50** is differently colored (e.g., yellow, red, blue), which permits the user of the home automation system **10** to associate each of the switches **16a**, **16b** and **16c**, or the room in which each of the switches **16a**, **16b** and **16c** is located, with a particular color. In our experience and testing, we have found that users of the home automation system **10** have less difficulty associating a switch (or the room in which the switch is located) with a color as compared with the alpha and/or numeric identifiers that are employed to program the transmitters and switches.

With reference to FIGS. 2 through 6, the housing **40** of the handheld transmitter **20** provided in this example is rela-

tively thin and flat, which provides the hand-held transmitter **20** with the appearance of a conventional switch or outlet plate. A mounting cradle **54** is provided for the hand-held transmitter **20**, which permits the hand-held transmitter **20** to be mounted in a convenient and accessible place. The mounting cradle **54** includes a planar rear wall **56** and a side wall **58** that bounds the bottom and portions of the left and right sides of the planar rear wall **56**. The planar rear wall **56** and the side wall **58** cooperate to form a transmitter cavity **60** into which the hand-held transmitter **20** may be removably placed. The side wall **58** is configured to wrap around the housing **40** of the hand-held transmitter **20**, but may alternatively engage slots (not shown) that are formed into the sides of the housing **40**.

Conventional threaded fasteners, which extend through the planar rear wall **56**, or preferably adhesives, such as an adhesive tape **62** that is applied to the planar rear wall **56**, may be employed to mount the mounting cradle **54** at a desired location. Those skilled in the art will appreciate that the mounting cradle **54** may be positioned in a manner such that the hand-held transmitter **20**, when mounted in the mounting cradle **54**, will have the appearance of a switch plate. Those skilled in the art will also appreciate that the mounting cradle **54** may be used in place of a switch plate (not shown) for covering an electrical switch box (not shown), as for example, in situations where a conventional toggle or dimmer switch (not shown) had been mounted in the electrical switch box and was used to toggle or otherwise control the power that was transmitted to a wall outlet (not shown). In this example, the toggle or dimmer switch may be removed such that the wall outlet is wired hot (i.e., wired to continuously receive electrical power from the power wire system **26**) and thereafter an electrical device, such as a floor lamp (not shown) that is coupled to the wall outlet is controlled via one of the switches **16a**, **16b** and **16c** of the home automation system **10**.

Returning to FIG. 1, the key fob transmitter **22** is configured in a manner that is similar to the hand-held transmitter **20** and as such, need not be discussed in significant detail herein. The key fob transmitter **22** includes only two keys **42e** and **42f**. The key **42e** is identical to the keys **42a**, **42b** and **42c** in that it is programmable (i.e., requested controller address and requested device address) and includes two function switches **44a** and **44b**. The key **42f** is identical to the key **42d** and in that it is also programmable (i.e., requested controller address).

With reference to FIGS. 1 and 7 through 12, the messenger hub **14** is illustrated to include a housing **70**, a power input portion **72**, an optional power output portion **74** and a controller **76**. The optional power output portion **74** permits the switch **16a** to be integrated with the messenger hub **14** at a relatively low cost, since elements that are similar to the housing **70**, the power input portion **72**, and the controller **76** are employed in the switches **16b** and **16c** and these elements are easily configured for and are not over utilized by the incorporation of the switch **16a** into the messenger hub **14**.

The housing **70** includes a housing assembly **80** and a housing cover **82**, which is hingedly coupled to the housing assembly **80** via a hinge **84**. The housing assembly **80** includes a first housing shell **86** and a second housing shell **88** that cooperate to form a cavity **90** into which the power input portion **72**, the power output portion **74** and the controller **76** are housed. The first and second housing shells **86** and **88** are injection molded from a suitable plastic. In the particular example provided, the first housing shell **86** is shown to include a power button aperture **92**, a controller

knob aperture **94**, a controller address window **96** and an optional switch aperture **98**, all of which will be discussed in more detail below. The housing cover **82**, which includes a power button window **100** cooperates with the first housing shell **86** to define an intermediate cavity **102**. The hinge **84** may be any appropriate hinge, including a living hinge or a piano wire hinge. In the particular embodiment illustrated, the hinge **84** includes a pair of first hinge tabs **110** and a pair of second hinge tabs **112**. The first hinge tabs **110** are integrally formed with the first housing shell **86** and extend inwardly into the cavity **90**. A spherical protrusion **114** is formed on the distal end of each of the first hinge tabs **110**. The second hinge tabs **112** are integrally formed with the housing cover **82**, extending rearwardly from the front surface of the housing cover **82**. A spherical recess **116** is formed into the distal end of each of the second hinge tabs **112**. The first and second hinge tabs **110** and **112** are coupled to one another such that the spherical protrusion **114** is seated in the spherical recess **116** to thereby define a hinge axis **118** about which the housing cover **82** is pivotably coupled to the housing assembly **80**. As those skilled in the art will appreciate, the hinge **84** is preferably configured such that the hinge axis **118** is concealed by the housing cover **82** when the housing cover **82** is closed against the housing assembly **80** to thereby provide the messenger hub **14** with a "clean" overall appearance.

The power input portion **72** includes a pair of conventional spade terminals **120** that are configured to matingly engage the female terminals of a conventional wall outlet (not shown) to permit the messenger hub **14** to be electrically coupled to the power wire system **26**. The power output portion **74** includes a pair of female terminals **124** that permits an electrical and/or security device, such as a lamp **30a**, to be electrically coupled to and controlled by the messenger hub **14**. The power input and output portions **72** and **74** are coupled to the controller **76** and the controller **76** selectively controls the transmission of electrical power to the power output portion **74**.

The controller **76** includes a control unit **130**, a power button **132**, a controller address selector **134** and an optional switch address selector **136**. The control unit **130** is conventionally configured and is operable for generating a message, for example using the X10 protocol, that is transmitted through the power input portion **72** and over the power wire system **26**. Optionally, the control unit **130** is also conventionally operable for receiving messages (in a suitable protocol such as the X10 protocol) that are transmitted over the power wire system **26** received through the power input portion **72**. The control unit **130** also conventionally includes an RF receiver **140** that is configured to receive RF commands **34** from the hand-held transmitter **20** and the key fob transmitter **22**. The RF receiver **140** includes an antenna **142**, which may be located within the cavity **90**, or coupled to the housing **70** in an externally extending (telescoping) manner as is illustrated in FIGS. **1**, **7** and **10**.

The power button **132** is electrically coupled to the control unit **130** and is operable for cycling or toggling power to the control unit **130**. The power button **132** preferably includes an internal illumination device (not specifically shown), such as an LED, which lights when the power button **132** is positioned in a manner that provides electrical power to the control unit **130**. The power button **132** extends through the power button aperture **92** in the first housing shell **86**, which permits it to be manipulated when the housing cover **82** is pivoted away from the housing assembly **80**. The power button **132** is aligned to the power button window **100** when the housing cover **82** is closed

against the housing assembly **80** and permits the user of the home automation system **10** to determine the status of the control unit **130** (i.e., off or on) without opening the housing cover **82** (since the power button **132** is illuminated).

The controller address selector **134** is a multi-position binary switch that is illustrated to include a rotary knob **150** having a knob portion **152** and a flange portion **154**. The knob portion **152** extends through the controller knob aperture **94** and into the intermediate cavity **102**, where it is accessible to the user of the home automation system **10** when the housing cover **82** is opened. The flange portion **154** extends around the perimeter of the knob portion **152** and includes a plurality of controller address indicia **156** (i.e., letter A through O), each of which corresponding to a predetermined controller address. The flange portion **154** is positioned in the cavity **90** such that the controller address indicia **156** to which the controller address selector **134** is set will be the only one of the controller address indicia **156** to show through the controller address window **96**. As is apparent from the construction of the particular knob **150** that is illustrated, the user is able to adjust the rotational position of the knob **150** with their thumb and fingers and as such, no tools, such as screwdrivers, are needed for setting the position of the knob **150**.

The switch address selector **136** is a multi-position binary switch that assigns a device address to the control unit **130**. In the particular embodiment illustrated, the switch address selector **136** includes a slider switch **160** that permits the switch address selector **136** to be positioned in one of two discrete positions (i.e., device address **1** or device address **9**) to thereby permit the user of the home automation system **10** to assign the power output portion **74** one of two different device addresses.

In the example provided, the power output portion **74** is normally maintained in an unpowered condition, wherein electrical energy is not transmitted thereto from the power wire system **26**. When an RF command **34** is generated by one of the remote transmitters **12** to enable the transmission of electrical power to the power output portion **74**, the control unit **130** enables power transmission to the power output portion **74**, as well as generates a message having a receipt address that includes its controller address and the device address of the switch **16a**. The message is transmitted through the power input portion **72** to the power wire system **26** and is thereafter received by the switches **16b** and **16c**. Any of the switches **16b** and **16c** that are configured to respond to a message having a receipt address that includes a controller address and a device address that are identical to the controller address of the messenger hub **14** and the device address of the switch **16a** will respond in a manner similar to that of the power output portion **74** of the messenger hub **14** (i.e., the switch **16a**). A more detailed description of the transmission of RF commands **34** and messages over the power wire system **26** may be found in U.S. Pat. No. 4,755,792 entitled "Security Control System" and assigned to Black & Decker Inc., which is hereby incorporated by reference as if fully set forth herein.

With reference to FIGS. **1** and **13** through **16**, the switches **16b** and **16c** are shown to be constructed in a manner that is similar to that of the messenger hub **14** but are physically smaller in size than the messenger hub **14**. As switches **16b** and **16c** are identically configured, only switch **16b** will be discussed in detail. The switch **16b** includes a housing **70b**, a power input portion **72b**, a power output portion **74b** and a controller **76b**. The power input portion **72b** and the power output portion **74b** are generally identical to the power input

portion 72 and the power output portion 74, respectively, and as such, need not be discussed in further detail.

The housing 70*b*, like the housing 70, includes a housing assembly 80*b*, with a first housing shell 86*b* and a second housing shell 88*b*, and a housing cover 82*b*. The second housing shell 88*b* and the housing cover 82*b* are identical to the second housing shell 88 and the housing cover 82 (FIG. 8), and as such, will not be discussed in further detail. The first housing shell 86*b* is generally similar to the first housing shell 86 (FIG. 8), except that the first housing shell 86*b* includes a switch aperture 98*b* is configured somewhat differently than the switch aperture 98 (FIG. 12), a switch scale 180 has been added proximate the switch aperture 98*b* and a power button aperture is not present. The switch aperture 136*b* and the switch scale 180 will be discussed in greater detail below.

The controller 76*b* includes a control unit 130*b*, the controller address selector 134 and a switch address selector 136*b*. The control unit 130*b* is conventionally configured and is operable for receiving messages that are transmitted over the power wire system 26 to the power input portion 72*b*. The controller address selector 134 is configured in an identical manner as the controller address selector 134 of the messenger hub 14. In this regard, the flange portion 154 of the controller address selector 134 is housed in the cavity 90*b* such that the controller address indicia 156 to which the controller address selector 134 is set will be the only one of the plurality of controller address indicia 156 to show through the controller address window 96 in the first housing shell 86*b*.

The switch address selector 136*b*, like the switch address selector 136, is a multi-position binary switch that assigns a device address to the switch 16*b*. In the particular embodiment illustrated, the switch address selector 136*b* is a rotary knob 190, having a knob portion 192 with a setting indicia 194 marked thereon. The setting indicia 194 is illustrated to be a radially outwardly projecting line, but those skilled in the art will understand that any setting indicia, including an arrow formed into the perimeter of the knob portion 192, may additionally or alternatively be employed. In the example provided, the switch address selector 136*b* is rotatable between 16 different positions (numbered 1 through 16) and thereby permits the user of the home automation system 10 to assign the switch 16*b* one of 16 different device addresses. As is apparent from the construction of the particular knob 190 that is illustrated, the user is able to adjust the rotational position of the knob 190 with their thumb and fingers and as such, no tools, such as screwdrivers, are needed for setting the position of the knob 190.

The switch scale 180 is illustrated to be sectioned into a plurality of differently colored sectors 182, with each of the colored sectors 182 being associable with a corresponding colored key cover 50. Adjustment of the switch address selector 136*b* to a position within a particular color-coded sector 182 does not automatically link or program a particular key to the switch 16*b*, but rather may be used to provide the user of the home automation system 10 with a means of visually associating the switch 16*b* with a particular key on the transmitters 12.

As with the power output portion 74 of the messenger hub 14, the power output portion 74*b* of the switch is normally maintained in an unpowered condition, wherein electrical energy is not transmitted to the power output portion 74*b* from the power wire system 26. When an RF command 34 is generated by one of the remote transmitters 12 to enable the transmission of electrical power to the power output portion 74*b* of a desired switch (e.g., switch 16*b*), the control

unit 130 of the messenger hub 14 generates a message having a receipt address that includes the controller address and a preprogrammed device address. The message is transmitted over the power wire system 26 to the power input portion 72*b* where it is received by the control unit 130*b* of the switch 16*b*. If the receipt address of the message includes a controller address that corresponds to a controller address to which the controller address selector 130*b* of the switch 16*b* is set and a device address that corresponds to a device address to which the switch address selector 136*b* of the switch 16*b* is set, the control unit 136*b* will enable the transmission of electrical power to the power output portion 74*b* of the switch 16*b*. Similarly, any of the other switches that are configured to respond to a message having a receipt address that includes a controller address and a device address that are identical to the controller address and the device address of the switch 16*b* will respond in a manner similar to that of the switch 16*b*.

Prior to the operation of the home automation system 10, the messenger hub 14, the switches 16*a*, 16*b* and 16*c*, the hand-held transmitter 20 and the key fob transmitter 22 must be programmed in a consistent manner. While the home automation system 10 need be set up in no particular order, the user may set up the home automation system 10 as follows:

- a) the controller address selector 134 of the messenger hub 14 is set to a desired controller address, such as "E";
- b) the switch address selector 136 of switch 16*a* is set to a desired device address, such as 1;
- c) the controller address selector 134 of switch 16*b* is set to the desired controller address to correspond to the controller address selector 134 of the messenger hub 14 (i.e., the controller address selector 134 of switch 16*b* is set to "E" in this example);
- d) the switch address selector 136*b* of switch 16*b* is set to a second desired device address, such as 9;
- e) the controller address selector 134 of switch 16*c* is set to the desired controller address to correspond to the controller address selector 134 of the messenger hub 14 (i.e., the controller address selector 134 of switch 16*c* is set to "E" in this example);
- f) the switch address selector 136*b* of switch 16*c* is set to a third desired device address, such as 5;
- g) the key 42*a* of the hand-held transmitter 20 is programmed with a desired controller address that corresponds to the controller address selector 134 of the messenger hub 14 (i.e., the requested controller address of the key 42*a* is programmed to "E" in this example);
- h) the key 42*a* of the hand-held transmitter 20 is programmed with a desired device address that corresponds to the device address of the switch 16*a* (i.e., the requested device address of the key 42*a* is programmed to "1" in this example);
- i) the key 42*b* of the hand-held transmitter 20 is programmed with a desired controller address that corresponds to the controller address selector 134 of the messenger hub 14 (i.e., the requested controller address of the key 42*a* is programmed to "E" in this example);
- j) the key 42*b* of the hand-held transmitter 20 is programmed with a desired device address that corresponds to the device address of the switch 16*b* (i.e., the requested device address of the key 42*b* is programmed to "9" in this example);
- k) the key 42*c* of the hand-held transmitter 20 is programmed with a desired controller address that corresponds to the controller address selector 134 of the

- messenger hub **14** (i.e., the requested controller address of the key **42c** is programmed to "E" in this example);
- l) the key **42c** of the hand-held transmitter **20** is programmed with a desired device address that corresponds to the device address of the switch **16c** (i.e., the requested device address of the key **42c** is programmed to "5" in this example);
 - m) key covers **50**, which correspond to the switch to which the key is associated, are assigned and matingly engaged to each of the keys **42a**, **42b** and **42c** (e.g., as the switch address selector of switches **16a**, **16b** and **16c**, are set to 1, 9 and 5, respectively, and as the 1, 9 and 5 device addresses lie within the boundaries of the red, yellow and blue colored indicia, respectively, on the switch scale **180**, the key covers **50** for the keys **42a**, **42b** and **42c** are red, yellow and blue, respectively);
 - n) the key **42d** of the hand-held transmitter **20** is programmed with a desired controller address that corresponds to the controller address selector **134** of the messenger hub **14** (i.e., the requested controller address of the key **42d** is programmed to "E" in this example);
 - o) the key **42e** of the key fob transmitter **22** is programmed with a desired controller address that corresponds to the controller address selector **134** of the messenger hub **14** (i.e., the requested controller address of the key **42e** is programmed to "E" in this example);
 - p) the key **42e** of the key fob transmitter **22** the key **42c** of the hand-held transmitter **20** is programmed with a desired device address that corresponds to the device address of any one of the switches **16a**, **16b** and **16c** that the user of the home automation system **10** desires to control with the key fob transmitter **22** (in this example, the requested device address of the key **42e** is set to "5", which permits the user of the home automation system **10** to control the switch **16c** with the key fob transmitter **22**);
 - q) the key **42f** of the key fob transmitter **22** is programmed with a desired controller address that corresponds to the controller address selector **134** of the messenger hub **14** (i.e., the requested controller address of the key **42f** is programmed to "E" in this example); and
 - r) appropriate electrical devices, which are lamps **30a**, **30b** and **30c** in the example provided, are electrically coupled to the switches **16a**, **16b** and **16c**, respectively.

The set-up or initialization of the home automation system **10** is rendered more intuitively obvious through its packaging **200** as shown in FIGS. **17** and **18**. The packaging **200** is provided in a book-like format with opposite covers **202**. At least one of the covers **202** is formed to include a plurality of cavities or wells **204**, with each of the wells **204** being configured to receive an associated one of the messenger hub **14**, the switches **16b** and **16c**, the handheld transmitter **20**, the key fob transmitter **22** and the key covers **50**. The wells **204** are also shown to include one or more finger recesses **208** that are configured in a manner that permits a person's finger or thumb to be inserted therein and engage an edge of the article in the well **204** so that the article may be more easily removed from the well **204**.

Illustrations **210** are preferably provided in the area proximate each well **204** to provide the installer with a visual indication of how the component is to be used and/or installed. For example, the illustrations **210a** and **210b** proximate the messenger hub **14** provide the installer with visual indications of how the messenger hub **14** is to be installed (i.e., plugged into a desired wall outlet) and how

the switch **16a** is to be used (i.e., an electrical device, such as a lamp, is plugged into the power outlet portion **74**).

Text instructions **212** are preferably included with the illustrations **210**. The text instructions **212** are not meant to completely eliminate detailed instructions for initializing the home automation system **10**, but rather to give a short synopsis of each step in the initializing process. In situations where the setting of the controller address or the device address of a component is discussed, the well **204** associated with these text instructions **212** is preferably enlarged so as to permit the housing cover of the component (e.g., housing cover **82b** of switch **16c**) to be positioned in an opened condition relative to the housing assembly (e.g., housing assembly **80b**) of the component.

While the home automation system **10** has been described thus far as being manually actuated and utilized in an entirely indoor environment, those skilled in the art will appreciate that the invention, in its broader aspects, may be constructed somewhat differently. For example, the home automation system **10'** may be configured in a manner that permits both indoor and outdoor use as illustrated in FIGS. **19** through **21**. In this arrangement, the home automation system **10'** is shown to include a plurality of switches **16b'** and **16c'**, which are substantially identical to the switches **16b** and **16c** of FIG. **1**, except that their housing **70b'** is sealed. In this regard, a first seal **300** seals the interface between the first and second housing shell halves **86b'** and **88b'** and a second seal **302** seals the interface between the first housing shell half **86b'** and the housing cover **82b'**. Each of the first and second seals **300** and **302** is illustrated to be an elastomeric seal, such as an O-ring, that is disposed in a corresponding seal ring groove **304**. Alternatively, the first seal **300** may be overmolded over the first and second housing shell halves **86b'** and **88b'**.

In the arrangement of FIGS. **22** and **23**, the home automation system **10''** is configured in a manner that is similar to the home automation system **10**, except that a second hand-held transmitter **20** and a PC interface link **400** have been provided. The PC interface link **400** is configured to be coupled to a conventional personal computer (PC) **402**, which permits the switches **16a**, **16b** and **16c** of the home automation system **10''** to be manually or automatically controlled via the PC **402**. Manual control of the home automation system **10''** is achieved when the user of the home automation system **10''** manually accesses a software program and uses the software program to alter the state of one or more of the switches **16a**, **16b** and **16c** in a desired manner. The PC interface link **400** receives data that is transmitted from the PC **402** and generates a message that is transmitted through the power wire system **26** in a manner that is described above. In this regard, the PC interface link **400** operates as a second messenger hub **14**, except that the messages are generated in response to data from the software running on the PC **402**, rather than from RF commands **34** that are generated by the transmitters **12**, such as the hand-held transmitters **20** and key fob transmitter **22**. Alternatively, the PC interface link **400** may include an RF transmitter for generating an RF command which is transmitted to the messenger hub **14**. The messenger hub **14** would respond to the RF command as if it had been generated by one of the hand-held transmitters **20** or the key fob transmitter **22**.

A fourth home automation system **10c** constructed in accordance with the teachings of the present invention is illustrated in FIG. **24**. In the particular example provided, the home automation system **10c** includes a messenger hub **14c**, a plurality of devices **500**, a remote transmitter **20c**, a key

13

fob transmitter **22c** and a universal remote transmitter **502**. The devices **500** include remotely controlled switches **16**, a motion detector **504**, a door lock **506** and a monitoring system **508**. The switches **16** may be lamp switches **16g**, appliance switches **16f**, bulb receivers **510** and/or hardwire switches **512**. Those skilled in the art will appreciate that home automation system **10c** may be configured in various different ways and that some configurations may omit one or more of the aforementioned components and/or add one or more components that may not be specifically illustrated in the drawings or discussed herein.

In FIGS. **25** and **26**, the messenger hub **14c** is illustrated to be generally similar to the messenger hub **14** illustrated in FIG. **10** and includes a housing **70c**, a power input portion **72**, an optional power output portion **74** and a controller **76c**. The power input portion **72** and the power output portion **74** are configured as described above and as such, will not be discussed in further detail. The controller **76c** includes a control unit **130c**, a power button **132**, a controller address selector **134**, an optional switch address selector **136c**, a run/learn switch **530** and an indicator light **532**. The control unit **130c** is generally similar to the control unit **130** described above but also includes programming capabilities that permit the user to associate various device addresses with one or more keys on the remote transmitter **20c**, the key fob transmitter **22c** and/or the universal remote transmitter **310**, which will be discussed in further detail, below. The power button **132** and the controller address selector **134** are substantially similar to those described above except that flange portion **154** of the knob **150** of the controller address selector **134** includes a plurality of controller address indicia **156** (i.e., letter A through P instead of A through O), each of which corresponding to a predetermined controller address. Also, although the knob **150** is preferably configured to permit the controller address selector **134** to be adjusted without tools, the knob **150** in the example provided includes a tool receiving recess **534** that is adapted to receive an associated tool (not shown) that permits the user to adjust the controller address selector **134** with a tool. In the embodiment illustrated, the tool receiving recess **534** is a slotted aperture that is configured to receive the flat blade of a conventional slotted screwdriver.

The switch address selector **136c** is generally similar to the switch address selector **136b** that is described in conjunction with the switches **16a**, **16b** and **16c**, above. More specifically, the switch address selector **136c** is a multi-position binary switch that permits the user to assign a device address to the power output portion **74** of the messenger hub **14c** without tools, such as screwdrivers. In the example provided, the knob **190c** of the switch address selector **136c** is, however, configured with a tool receiving recess **538** that is adapted to receive an associated tool (not shown) that permits the user to adjust the switch address selector **136c** with a tool. In the embodiment illustrated, the tool receiving recess **538** is a slotted aperture that is configured to receive the flat blade of a conventional slotted screwdriver.

Each of the positions in the switch scale **180** is associated with a color-coded sector **182** that will be discussed in further detail, below. In the particular example provided, the position “**1**” is located in a red colored sector **182** and associated with a first device address, each of the positions “**2**”, “**3**” and “**4**” is located in a gray colored sector **182** and associated with a second, third and fourth device address, respectively, each of the positions “**5**”, “**6**” and “**7**” is located in a green colored sector **182** and associated with a fifth, sixth and seventh device address, respectively, each of the

14

positions “**8**”, “**9**” and “**10**” are located in a yellow colored sector and associated with an eighth, ninth and tenth switch device address, respectively, each of the positions “**11**”, “**12**” and “**13**” are located in a blue colored sector **182** and associated with an eleventh, twelfth and thirteenth device address, respectively, and each of the positions “**14**”, “**15**” and “**16**” are located in a black colored segment and associated with a fourteenth, fifteenth and sixteenth device address, respectively. Those skilled in the art will appreciate that any colors may be used to designate the various sectors **182**, but in the example provided, the colors have been selected so as to permit persons with various forms of color blindness (e.g., red-green) to differentiate between the various colored sectors **182** of the switch scale **180**.

The run/learn switch **530** is a slider-type switch in the example provided that permits a user to toggle the control unit **130c** between a run mode, which permits the user to actuate a user programmed “mood” function, and a learn mode, which permits the user to program the “mood” function. The indicator light **532** is electrically coupled to the control unit **130c** and provides a visual indication of the receipt of radio frequency data from a remote transmitter (e.g., the hand-held remote transmitter **20c**). It will be appreciated that there can be alternate names for the “mood” functions, such as but not limited to “group” functions.

With reference to FIGS. **25**, **26** and **28**, the housing **70c** is modified somewhat from the housing **70** described above so as to accommodate the switch address selector **136c**, the run/learn switch **530** and the indicator light **532**. Furthermore, a protrusion **540** is formed on the housing cover **82c** and positioned thereon so as to contact the run/learn switch **530** if the housing cover **82c** is closed against the housing assembly **80c** while the run/learn switch **530** is in the learn position. The housing assembly **80c** further includes recessed areas **544** that are positioned on the lateral sides of the housing assembly **80c** to permit the user to grip the housing assembly **80c** or the housing cover **82c** as desired to withdraw the messenger hub **14c** from an electrical outlet (not illustrated) or to open the housing cover **82c**.

Returning to FIG. **24**, the lamp and appliance switches **16g** and **16f** are configured almost identically to the switches **16a**, **16b** and **16c** discussed above, except that the housing **70c'** of the switches **16g** and **16f** includes recessed areas (not specifically shown) that are positioned on the lateral sides of the housing **70c'** to permit the user to grip the housing **70c'** or the housing cover **82c'** as desired to withdraw the switch **16** from an electrical outlet (not illustrated) or to open the housing cover **82c'**. In the example provided, the lamp switches **16g** are configured to be employed only in conjunction with indoor incandescent lamps that draw a predetermined maximum amount of electrical energy, such as 300 watts of electrical power. Additionally, the control unit **76c'** of the lamp switches **16g** include a generic switch type address (i.e., a generic lamp switch address). In contrast, the appliance switches **16f** may be employed with various indoor appliances (i.e., the appliance switches **16f** are not restricted for use with only indoor incandescent lamps) that draw a predetermined maximum amount of electrical power, such as 500 watts of electrical power. The control unit **76c'** of the appliance switches **16f** include a generic switch type address (i.e., a generic appliance switch address), while the power input portion **72b'** and power output portion **74b'** of the appliance switch **16f** are configured with a standard three conductor (i.e., grounded) configuration.

The bulb receivers **510** and hardwire switches **512** are similar to products that are commercially available from various sources such as the Socket Rocket and the Wall

15

Switch Module, respectively, which are marketed by X10.com. Briefly, the bulb receiver **510** may be programmed via a remote transmitter (e.g., the hand-held remote transmitter **20c**) by screwing the bulb receiver **510** into the socket **550** of a lamp **552**, applying electrical power to the socket **550** and transmitting an RF signal **34** to the messenger hub **14c** a predetermined number of times (e.g., 3 times). In response, the messenger hub **14c** repetitively generates a message that causes the switches **16** having a common controller address and a device address associated with the RF signal **34** to enable the transmission of electrical power. When the bulb receiver **510** receives this message the predetermined number of times, the bulb receiver **510** will automatically “learn” both the controller address and a device address associated with the RF signal **34**. Thereafter, the bulb receiver **510** can be operated by the user in a manner that is identical to that of the lamp and appliance switches **16g** and **16f**.

The hardwire switches **512** are functionally similar to the lamp switches **16g**, and differ in that they are packaged in a way that permits them to be installed in a conventional electrical junction or outlet box (not shown) and coupled in the conventional manner that toggle switches are coupled the electrical wiring of a house (i.e., their power input and output portions are configured to be coupled directly to the wiring of the electrical power system **26**). The hardwire switches **512** include a rotary controller address selector **560** and a rotary switch address selector **562** that permit them to be initialized in a manner that is identical to that of the lamp and appliance switches **16g** and **16f**.

The motion detector **504** is similar to products that are commercially available from various sources such as the EagleEye Indoor/Outdoor Motion Sensor and the ActiveEye Indoor/Outdoor Motion Sensor marketed by X10.com. Briefly, the motion detector **504**, which is electronically programmable in a manner similar to that described above for the bulb receiver **510** to initialize it with a controller address and a device address, is a battery-powered motion detector that generates an RF signal **34**, which when received by the messenger hub **14c** may be employed to cause the messenger hub **14c** to activate various other devices (e.g., switches **16** and/or the monitoring system **508**) upon the sensing of motion. If no motion is sensed after a user settable amount of time has elapsed since the motion detector **504** last sensed motion, the motion detector **504** will generate another RF signal **34**, which when received by the messenger hub **14c** may be employed to cause the messenger hub **14c** to deactivate the various devices that had been activated upon the sensing of motion.

The monitoring system **508** is similar to products that are commercially available from various sources such as the XCam2 Kit marketed by X10.com. Briefly, the monitoring system **508** includes a receiver **570** and a camera **572**. In the particular example provided, each of the receiver **570** and the camera **572** include a power supply **574a** and **574b**, respectively, that permit these units to be electrically coupled to the power wire system **26**. Alternatively, one or both of the receiver **570** and the camera **572** may be battery powered.

The power supply **574a** for the receiver **570** is configured in a manner that is similar to the lamp and appliance switches **16g** and **16f** and may be initialized (i.e., set to a controller address and a device address) in a similar manner. The power output portion **74d**, however, is configured with a power cord **580** that is configured to be coupled to the receiver **570**. The power supply **574b** for the camera **572**

16

couple the camera **572** to a constant source of electrical power (i.e., the power supply **574b** does not cycle power to the camera **572**).

Upon activation of the power supply **574a** by the messenger hub **14c** (i.e., in response to the generation of a message by the messenger hub that includes a common controller address and a common device address), the receiver **570** generates an RF command **34'** that causes the camera **572** to activate. The camera **572**, which converts optical images into electronic data **34''**, sends the data **34''** to the receiver **570** in an RF format. The receiver **570** converts the data from the RF format into a conventional video signal type, which may thereafter be transferred from the receiver **570** to a conventional video recorder (not shown) in a conventional manner. Deactivation of the power supply **574a** similarly causes the camera **572** to cease the transmission of data. Alternatively, the power supply **574b** may be activated by the messenger hub **14c** (i.e., in response to the generation of a message by the messenger hub that includes a common controller address and a common device address) rather than via an RF command **34'**.

The door lock **506** is similar to products that are commercially available from Kwikset of Lake Forest, Calif., such as the Kwikset Maximum Security Remote Keyless Entry Deadbolts and Handlesets. The door lock **506** is described in greater detail in U.S. patent application Ser. No. 09/062,156 entitled “Remotely Controlled Door Lock System”, U.S. Pat. No. 5,857,365 entitled “Electronically Operated Lock” and WIPO International Application No. PCT/US00/21822 entitled “Remote Entry Lockset”, the disclosures of which are hereby incorporated by reference as if fully set forth herein. Briefly, the door lock **506** includes a controller **590** and a lock **592**. The lock **592** is conventionally movable between a locked condition and an unlocked condition and may be moved therebetween either manually or automatically by the controller **590** in response to an RF signal **34d** generated by a hand-held remote transmitter (e.g., the hand-held remote transmitter **20c** or the key fob transmitter **22c**).

Like the hand-held remote transmitter **20**, the remote transmitter **200** is conventionally operable for transmitting a plurality of RF signals **34** to communicate an RF command to the messenger hub **14**. As those skilled in the art will appreciate from this disclosure, any wireless communication between various components of the home automation system **10** may be made via any type of electromagnetic energy. As such, the hand-held remote transmitter **20c**, and the messenger hub **14** may be configured in the alternative to communicate via any other suitable form of electromagnetic wave communication. In the particular example illustrated in FIGS. **29** and **30**, the remote transmitter **20c** includes a housing **40c**, an optional housing cover **40c'** and a plurality of function switches **44c** that include a selector wheel switch **600**, a set of zone switches **602**, a set of device address switches **604**, first and second sets of mood switches **606** and **608**, respectively, and a set of whole house switches **610**.

The housing cover **40c'** is movable between a closed position, which is illustrated in FIG. **29**, and an open position, which is illustrated in FIG. **30**. The housing cover **40c'** includes a window **614**, which permits the user to view the setting of the selector wheel switch **600** when the housing cover **40c'** is placed in the closed position, and an access aperture **616**. A portion of the selector wheel switch **600** extends through the access aperture **616** when the housing cover **40c'** is closed to thereby permit the user to change the setting of the selector wheel switch **600** without opening the housing cover **40c'**. The outer perimeter or edge

17

618 of the selector wheel switch 600 is preferably textured (e.g., reeded) to permit the user to more easily grip the selector wheel switch 600.

In the example provided, the selector wheel switch 600 is segregated into six different zones 620, with each zone 620 being identified by a color corresponding to an associated one of the sectors 182 on the switch scale 180. With reference to FIG. 31, each zone 620 further includes the indicia 622 of one or more of the switch positions that are associated with the switch scale 180 (a number from 1 to 16 in the example provided). In the embodiment provided, zone 620a is associated with the red colored sector 182 and includes indicia 622 designating its association with switch position "1", zone 620b is associated with the gray colored sector 182 and includes indicia 622 designating its association with switch positions "2" through "4", zone 620c is associated with the green colored sector 182 and includes indicia 622 designating its association with switch positions "5" through "7", zone 620d is associated with the yellow colored sector 182 and includes indicia 622 designating its association with switch positions "8" through "10", zone 620e is associated with the blue colored sector 182 and includes indicia 622 designating its association with switch positions "11" through "13" and zone 620f is associated with the black colored sector 182 and includes indicia 622 designating its association with switch positions "14" through "16". Placement of the selector wheel switch 600 into a desired or selected zone 620 aligns the zone 620 with the window 614 in the housing cover 40c' to thereby permit the user to view therethrough the color of the selected zone 620. Optionally, as illustrated in FIG. 29, the window 614 may be sized large enough to permit the user to also view the indicia 622 associated with the selected zone 620.

Returning to FIGS. 24 and 30, the set of zone switches 602, which are optional and include an "on" button 650 and an "off" button 652 in the example provided, permit the user to activate or de-activate all of the switches 16 associated with the selected zone 620 with a single touch of a button. More specifically, actuation of the "on" button 650 or "off" button 652 will generate an RF signal 34 that when received by the messenger hub 14c will cause the messenger hub 14c to generate a message that is transmitted through the power input portion 72 and over the power wire system 26. On receipt of this message, any of the switches 16 that have been set to a common controller address (i.e., the controller address of the switch 16 matches that of the messenger hub 14c) and a switch address that corresponds to any of the switch positions that are included in a colored sector 182 that matches the color of the zone 620. For example, if the selector wheel switch 600 were positioned in the blue zone 620e and the "on" button 650 were pressed, the messenger hub 14c would generate a message that would cause any of the switches 16 that were set to a common controller address and whose switch address selector 136b was placed in the blue colored sector 182 (i.e., to switch positions "11", "12" or "13" in the example provided) to enable the transmission of electrical power to the power output portion 74b of the switch 16. As we do not expect that the set of zone switches 602 will be used on a frequent basis, the we have arranged the hand-held remote transmitter 20c such that the set of zone switches 602 is covered by the housing cover 40c' when the housing cover 40c' is positioned in the closed position.

The device address switches 604, which are rocker-type switches 670a, 670b and 670c in the example provided, permit the user to independently activate or de-activate the switches 16 that have been assigned a switch position that

18

corresponds with the indicia 622 on the selected zone 620 of the selector wheel switch 600. For example, rotation of the selector wheel switch 600 to the green zone 620e automatically associates the rocker-type switches 670a, 670b and 670c with switch positions corresponding to indicia "5", "6" and "7", respectively. Accordingly, rocking the rocker-type switch 670a to the "on" position in this example will generate an RF signal 34 that when received by the messenger hub 14c will cause the messenger hub 14c to generate a message that would cause any of the switches 16 that are set to a common controller address and whose switch address selector 136b was placed in the "5" position to enable the transmission of electrical power to the power output portion 74b of the switch 16. Likewise, rocking the rocker-type switch 670c to the "off" position in this example will generate an RF signal 34 that when received by the messenger hub 14c will cause the messenger hub 14c to generate a message that would cause any of the switches 16 that are set to a common controller address and whose switch address selector 136b was placed in the "7" position to disable the transmission of electrical power to the power output portion 74b of the switch 16.

With regard to the setting of the selector wheel switch 600 to the red zone 620a, which includes a single indicia 622 designating its association with a switch position of "1", the rocker-type switches 670a and 670c are inoperative, so that only rocker-type switch 670b may be employed to activate or de-activate switches 16 that are set to a common controller address and whose switch address selector 136b was placed in the "1" position. Alternatively, the hand-held remote transmitter 20c may be configured such that each of the rocker-type switches 670a, 670b and 670c may be employed to activate or de-activate switches 16 that are set to a common controller address and whose switch address selector 136b was placed in the "1" position.

The first and second sets of mood switches 606 and 608 are generally similar and as such, only the first set of mood switches 606 will be discussed in detail. The first set of mood switches 606 includes an "on" button 680 and an "off" button 682 in the particular example illustrated that permit the user to control the operation of one or more switches 16 that are associated with one or more predetermined device addresses. As noted above, the "mood" function is user programmable so that the user may select the device addresses (up to a predetermined maximum quantity) that are to be controlled.

To program the "mood" function associated with the first set of mood switches 606, the run/learn switch 530 on the messenger hub 14c is placed in the learn position (with the messenger hub 14c coupled to the power wire system 26) and the "on" button 680 associated with the first set of mood switches 606 is pressed to thereby transmit an RF signal 34 to the messenger hub 14c to indicate that the "mood" function for the first set of mood switches 606 is to be programmed. The indicator light 532 on the messenger hub 14c, which is maintained normally in a constant or steady illuminated condition, will flicker as data is being transmitted to and processed by the control unit 130c. Once the indicator light 532 returns to the steady illuminated condition (i.e., when it no longer flickers), the control unit 130c is ready to be programmed with up to a predetermined maximum number of device addresses (in the example provided, the predetermined maximum number of device addresses is four).

To program a device address, the user rotates the selector wheel switch 600 as necessary to a desired zone 620 to associate the device address switches 604 with indicia 622

associated with desired switch positions (which thereby associates the device address switches **604** with corresponding device addresses). Thereafter, the user rocks a rocker-type switch (i.e., rocker-type switches **670a**, **670b** or **670c**) to the “on” position to transmit an RF signal **34** to the control unit **130c** that causes the control unit **130c** to associate a particular device address with the “mood” function. Thereafter, the user may rotate the selector wheel switch **600** as necessary and rock one of the rocker-type switches to the “on” position when the indicator light **532** has returned to a steady illuminated condition to associate another particular device address with the “mood” function. Once the “mood” function has been programmed, the user switches the run/learn switch **530** to the run position. Thereafter, when the “on” or “off” buttons **680** and **682** of the first set of mood switches **606** are actuated, the control unit **130c** of the messenger hub **14c** will generate messages which cause any of the switches **16** associated with the preprogrammed “mood” function to enable or disable, respectively, the transmission of electrical power to the power output portion **74b** of the switch **16**.

To further illustrate the setting of a “mood” function, a non-limiting example is provided herein. With the messenger hub **14c** prepped (i.e., the messenger hub **14c** coupled to the power wire system **26** and the run/learn switch **530** set to the learn position), the user depresses the “on” button **680** associated with the second set of mood switches **608** to thereby initiate the programming of the second “mood” function. In this example, it is desired to program the second “mood” function with device addresses that are associated with switch positions “9”, “11”, “12” and “16”. Accordingly, the user rotates the selector wheel switch **600** to the yellow zone **620d** and rocks the rocker-type switch **670b** to the “on” position. The user then rotates the selector wheel switch **600** to the blue zone **620e** and (when the indicator light **532** has returned to a steady illuminated condition) rocks the rocker-type switch **670a** to the “on” position, waits for the indicator light **532** to return to a steady illuminated condition, and then rocks the rocker-type switch **670b** to the “on” position. Thereafter, the user rotates the selector wheel switch **600** to the black zone **620f** and (when the indicator light **532** has returned to a steady illuminated condition) rocks the rocker-type switch **670c** to the “on” position. When the indicator light **532** has returned to a steady illuminated condition, the user returns the run/learn switch **530** to the run position and thereafter can activate or deactivate devices (e.g., switches **16**) that are set to a controller address that is common with that to which the messenger hub **14c** has been set and whose device address is set to device addresses corresponding to the switch positions “9”, “11”, “12” and “16”.

To further illustrate the programming of the “mood” function in the particular embodiment provided, assume that prior to switching the run/learn switch **530** to the run position in the preceding example, the user rocks the rocker-type switch **670b** to the “on” position. As the maximum number of device addresses that can be associated with a “mood” function in this example has been identified as being four, the control unit **130c** would effectively delete the first entered device address associated with the particular “mood” function and store the newly entered device address. In this example, the control unit **130c** would effectively delete the device address associated with the switch position “9” and program a switch position of “15” (so that the second “mood” function would be programmed to device addresses corresponding to the switch positions “11”, “12”, “16” and “15”).

The set of whole house switches **610** is illustrated in the example provided to include an “on” button **690** and an “off” button **692**. Actuation of the “on” button **690** generates an RE signal **34** that when received by the messenger hub **14c** causes the messenger hub **14c** to generate a message that causes a predetermined first set of device types to activate, which in the particular example provided, consists only of lamp switches **16g** that are set to a controller address that is common with that to which the messenger hub **14c** is set. In contrast, actuation of the “off” button **692** generates an RF signal **34** that when received by the messenger hub **14c** causes the messenger hub **14c** to generate a message that causes a predetermined second set of device types to deactivate, which in the particular example provided, consists of both lamp switches **16g** and appliance switches **16f** that are set to a controller address that is common with that to which the messenger hub **14c**.

Returning to FIG. **24**, the key fob transmitter **22c** is generally similar to the key fob transmitter **22** of FIG. **1** except that it is configured with a set of device address switches **604'**, a first set of mood switches **606**, a set of whole house switches **610** and a set of door lock switches **696**. The first set of mood switches **606** and the set of whole house switches **610** are substantially similar to that which are described above in conjunction with the hand-held remote transmitter **20c** and as such, need not be described in further detail. In the example provided, the device address switches **604'** includes a single set of preprogrammed switches that are associated with a predetermined device address, such as the device address that corresponds to a switch position of “1”. The device address switches **604'** may be associated with a given messenger hub **14c** or the messenger hub **14c** may be initialized in a conventional and well known manner to accept RF commands **34** from one or more particular key fob transmitters **22c**. The door lock switches **696** are configured to transmit RF commands **34d** that are accepted by the controller **590** of the door lock **506** to thereby permit the user to remotely lock and unlock a door (not shown).

The universal remote transmitter **502** is similar to products that are commercially available from various sources such as the Platinum Remote marketed by X10.com. Briefly, the universal remote transmitter **502** may be employed to control various electronic components, such as televisions **700**, video cassette recorders **702**, DVD players, laser disk players, satellite receivers, stereo receivers, cassette decks, compact disk players, etc., as well as the various devices **500** of the home automation system **10c**. In the particular example provided, the universal remote transmitter **502** includes a pre-programmed memory into which the infrared (IR) command structure for controlling various commercially available electronic equipment (e.g., televisions, etc.) has been stored. To associate the universal remote transmitter **502** with a particular device, the user need only switch the universal remote transmitter **502** into a “learn” mode wherein a button (e.g., a button labeled TV) is associated with an appropriate IR command structure. Alternatively or additionally, the universal remote transmitter **502** may “learn” various IR commands directly from a remote transmitter that has been provided with the electronic device. Such learning techniques are well known in the art and as such, need not be set forth in detail herein. Those skilled in the art will appreciate that the teachings of the present invention may be incorporated into the universal remote transmitter **502** to improve its functionality and convenience. For example, the universal remote transmitter **502** may additionally be equipped with mood function switches,

21

whole house function switches and a selector wheel switch or an equivalent thereof that permits the user to quickly and easily associate the RF commands that are generated with a desired device address.

While the invention has been described in the specification and illustrated in the drawings with reference to various preferred embodiments, it will be understood by those skilled in the art that various changes may be made and equivalents may be substituted for elements thereof without departing from the scope of the invention as defined in the claims. In addition, many modifications may be made to adapt a particular situation or material to the teachings of the invention without departing from the essential scope thereof. Therefore, it is intended that the invention not be limited to the particular embodiment illustrated by the drawings and described in the specification as the best mode presently contemplated for carrying out this invention, but that the invention will include any embodiments falling within the foregoing description and the appended claims.

What is claimed is:

1. A home automation system comprising:

a messenger hub having a power input portion and a controller, the power input portion of the messenger hub including a pair of terminals that are adapted for coupling to an electrical power line, the controller of the messenger hub being configured to selectively generate an electronic message that is transmitted through the electrical power line; and

a remotely controlled switch having a power input portion, a power output portion, a controller and a housing, the power input portion of the remotely controlled switch including a pair of terminals that are adapted for coupling to the electrical power line and receiving the electronic message, the controller of the remotely controlled switch being coupled to the power input portion of the remotely controlled switch and configured to selectively enable or disable transmission of electrical power between the power input portion of the remotely controlled switch and the power output portion in response to the electronic message, the housing having first and second portions, which cooperate to define a cavity into which the controller of the remotely controlled switch is housed, and a seal member that is disposed between the first and second portions.

2. The home automation system of claim 1, wherein the housing further comprises a cover and a cover seal, the cover being hingedly coupled to one of the first and second portions and movable between an open position, which provides access to the controller of the remotely controlled switch, and a closed position, the cover seal being employed to form a seal between the cover and the one of the first and second portions.

22

3. A home automation system comprising:

a plurality of remotely controlled switches, each of the remotely controlled switches being settable to a selected device address;

a messenger hub that is configured to transmit messages through an electrical power line for controlling the remotely controlled switches; and

a hand-held remote transmitter for transmitting commands to the messenger hub, the messenger hub being responsive to the commands to activate one or more of the remotely controlled switches, the hand-held remote transmitter including:

a first switch having a plurality of zones, each of the zones being associated with a set of device addresses, the first switch being selectively positionable into a desired zone, the set of device addresses including one or more of the device addresses to which the remotely controlled switches may be set; and

at least one second switch, each second switch being associated with a single device address in the set of device addresses such that operation of one of the second switches causes the hand-held remote transmitter to generate a command that causes the messenger hub to generate a message to activate any remotely controlled switch that has been set to a device address corresponding to the single device address.

4. The home automation system of claim 3, wherein changing the first switch to another desired zone associates each second switch with a different set of device address.

5. The home automation system of claim 3, wherein the first switch is a rotary switch.

6. The home automation system of claim 3, wherein a maximum quantity of device addresses that may be included in the set of device addresses is equal to a quantity of the second switches.

7. The home automation system of claim 3, wherein the set of device addresses associated with the desired zone includes only one device address and each of the second switches is associated with the only one device address.

8. The home automation system of claim 3, wherein the hand-held remote transmitter further comprises a zone switch, the zone switch being associated with each of the device addresses in the set of device addresses such that operation of the zone switch causes the hand-held remote transmitter to generate a command that causes the messenger hub to generate at least one message to activate any remotely controlled switch that has been set to a device address corresponding to one of the device addresses in the set of device addresses.

* * * * *

UNITED STATES PATENT AND TRADEMARK OFFICE
Certificate

Patent No. 7,082,339 B2

Patented: July 25, 2006

On petition requesting issuance of a certificate for correction of inventorship pursuant to 35 U.S.C. 256, it has been found that the above identified patent, through error and without any deceptive intent, improperly sets forth the inventorship.

Accordingly, it is hereby certified that the correct inventorship of this patent is: Christopher Murray, Baltimore, MD (US); Cory Sorice, Towson, MD (US); James R. Raskin, Ellicott City, MD (US); Carolyn M. Martin, Baltimore, MD (US); and William Frederick, Bel Air, MD (US).

Signed and Sealed this Twenty-fifth Day of March 2008.

DAVID VINCENT
Supervisory Patent Examiner
Art Unit 2129